

CMOS 4-BIT SINGLE CHIP MICROCOMPUTER  
**S5U1C62920D** Manual  
(Development Software Tool for S1C62920)

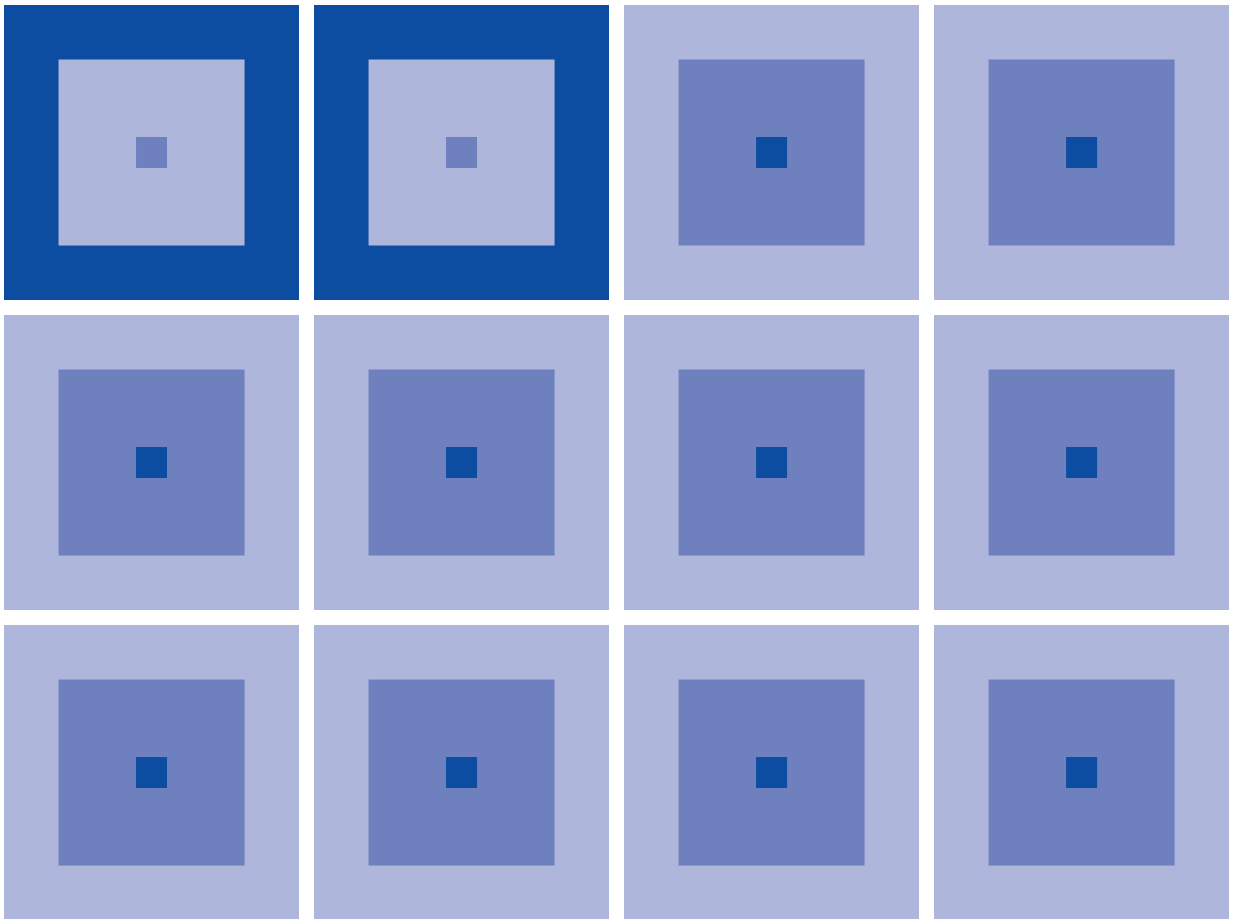

## ***NOTICE***

---

*No part of this material may be reproduced or duplicated in any form or by any means without the written permission of Seiko Epson. Seiko Epson reserves the right to make changes to this material without notice. Seiko Epson does not assume any liability of any kind arising out of any inaccuracies contained in this material or due to its application or use in any product or circuit and, further, there is no representation that this material is applicable to products requiring high level reliability, such as medical products. Moreover, no license to any intellectual property rights is granted by implication or otherwise, and there is no representation or warranty that anything made in accordance with this material will be free from any patent or copyright infringement of a third party. This material or portions thereof may contain technology or the subject relating to strategic products under the control of the Foreign Exchange and Foreign Trade Law of Japan and may require an export license from the Ministry of International Trade and Industry or other approval from another government agency.*

MS-DOS, Windows, Windows 95, Windows 98 and Windows NT are registered trademarks of Microsoft Corporation, U.S.A.  
PC-DOS, PC/AT, PS/2, VGA, EGA and IBM are registered trademarks of International Business Machines Corporation, U.S.A.  
NEC PC-9800 Series and NEC are registered trademarks of NEC Corporation.  
All other product names mentioned herein are trademarks and/or registered trademarks of their respective owners.

## The information of the product number change

Starting April 1, 2001, the product number will be changed as listed below. To order from April 1, 2001 please use the new product number. For further information, please contact Epson sales representative.

## Configuration of product number

Devices

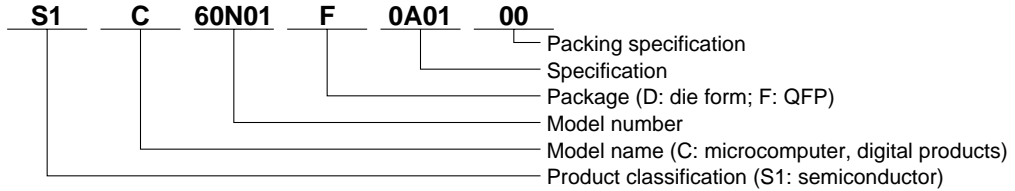

Development tools

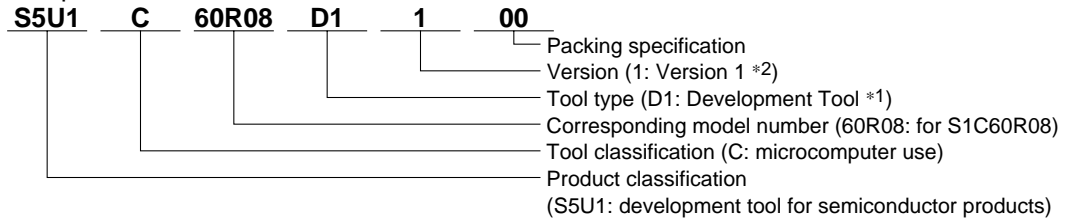

\*1: For details about tool types, see the tables below. (In some manuals, tool types are represented by one digit.)

\*2: Actual versions are not written in the manuals.

## Comparison table between new and previous number

S1C60 Family processors

Previous No.	New No.
E0C6001	S1C60N01
E0C6002	S1C60N02
E0C6003	S1C60N03
E0C6004	S1C60N04
E0C6005	S1C60N05
E0C6006	S1C60N06
E0C6007	S1C60N07
E0C6008	S1C60N08
E0C6009	S1C60N09
E0C6011	S1C60N11
E0C6013	S1C60N13
E0C6014	S1C60140
E0C60R08	S1C60R08

S1C62 Family processors

Previous No.	New No.
E0C621A	S1C621A0
E0C6215	S1C62150
E0C621C	S1C621C0
E0C6S27	S1C6S2N7
E0C6S37	S1C6S3N7
E0C623A	S1C6N3A0
E0C623E	S1C6N3E0
E0C6S32	S1C6S3N2
E0C6233	S1C62N33
E0C6235	S1C62N35
E0C623B	S1C6N3B0
E0C6244	S1C62440
E0C624A	S1C624A0
E0C6S46	S1C6S460

Previous No.	New No.
E0C6247	S1C62470
E0C6248	S1C62480
E0C6S48	S1C6S480
E0C624C	S1C624C0
E0C6251	S1C62N51
E0C6256	S1C62560
E0C6292	S1C62920
E0C6262	S1C62N62
E0C6266	S1C62660
E0C6274	S1C62740
E0C6281	S1C62N81
E0C6282	S1C62N82
E0C62M2	S1C62M20
E0C62T3	S1C62T30

## Comparison table between new and previous number of development tools

Development tools for the S1C60/62 Family

Previous No.	New No.
ASM62	S5U1C62000A
DEV6001	S5U1C60N01D
DEV6002	S5U1C60N02D
DEV6003	S5U1C60N03D
DEV6004	S5U1C60N04D
DEV6005	S5U1C60N05D
DEV6006	S5U1C60N06D
DEV6007	S5U1C60N07D
DEV6008	S5U1C60N08D
DEV6009	S5U1C60N09D
DEV6011	S5U1C60N11D
DEV60R08	S5U1C60R08D
DEV621A	S5U1C621A0D
DEV621C	S5U1C621C0D
DEV623B	S5U1C623B0D
DEV6244	S5U1C62440D
DEV624A	S5U1C624A0D
DEV624C	S5U1C624C0D
DEV6248	S5U1C62480D
DEV6247	S5U1C62470D

Previous No.	New No.
DEV6262	S5U1C62620D
DEV6266	S5U1C62660D
DEV6274	S5U1C62740D
DEV6292	S5U1C62920D
DEV62M2	S5U1C62M20D
DEV6233	S5U1C62N33D
DEV6235	S5U1C62N35D
DEV6251	S5U1C62N51D
DEV6256	S5U1C62560D
DEV6281	S5U1C62N81D
DEV6282	S5U1C62N82D
DEV6S27	S5U1C6S2N7D
DEV6S32	S5U1C6S3N2D
DEV6S37	S5U1C6S3N7D
EVA6008	S5U1C60N08E
EVA6011	S5U1C60N11E
EVA621AR	S5U1C621A0E2
EVA621C	S5U1C621C0E
EVA6237	S5U1C62N37E
EVA623A	S5U1C623A0E

Previous No.	New No.
EVA623B	S5U1C623B0E
EVA623E	S5U1C623E0E
EVA6247	S5U1C62470E
EVA6248	S5U1C62480E
EVA6251R	S5U1C62N51E1
EVA6256	S5U1C62N56E
EVA6262	S5U1C62620E
EVA6266	S5U1C62660E
EVA6274	S5U1C62740E
EVA6281	S5U1C62N81E
EVA6282	S5U1C62N82E
EVA62M1	S5U1C62M10E
EVA62T3	S5U1C62T30E
EVA6S27	S5U1C6S2N7E
EVA6S32R	S5U1C6S3N2E2
ICE62R	S5U1C62000H
KIT6003	S5U1C60N03K
KIT6004	S5U1C60N04K
KIT6007	S5U1C60N07K



## PREFACE

---

This manual mainly explains the outline of the development support tool for the 4-bit Single Chip Micro-computer S1C62920.

Refer to the "S1C62 Family Development Tool Reference Manual" for the details (common to all models) of each development support tool. Manuals for hardware development tools are separate, so you should also refer to the below manuals.

<i>Development tools</i>	☞ S1C62 Family Development Tool Reference Manual S5U1C621C0E Manual (Evaluation Board for S1C621C0/62920) S5U1C62000H Manual (S1C60/62 Family In-Circuit Emulator)
<i>Device (S1C62920)</i>	☞ S1C62920 Technical Manual
<i>Instructions</i>	☞ S1C6200/6200A Core CPU Manual

\* In this manual, "ICE" and "evaluation board" indicate S5U1C62000H and S5U1C621C0E, respectively.

## CONTENTS

---

<b>1 COMPOSITION OF DEVELOPMENT SUPPORT TOOL</b>	<b>1</b>
1.1 Configuration of S5U1C62920D .....	1
1.2 Developmental Environment .....	1
1.3 Development Flow .....	2
1.4 Installation .....	3
<b>2 DEVELOPMENT TOOL MANAGEMENT SYSTEM DMS6200</b>	<b>4</b>
2.1 DMS6200 Outline .....	4
2.2 DMS6200 Quick Reference .....	4
<b>3 CROSS ASSEMBLER ASM6292</b>	<b>5</b>
3.1 ASM6292 Outline .....	5
3.2 S1C62920 Restrictions .....	5
3.3 ASM6292 Quick Reference .....	6
<b>4 FUNCTION OPTION GENERATOR FOG6292</b>	<b>8</b>
4.1 FOG6292 Outline .....	8
4.2 S1C62920 Option List .....	8
4.3 Option Specifications and Selection Message .....	10
4.4 FOG6292 Quick Reference .....	15
4.5 Sample File .....	17
<b>5 SEGMENT OPTION GENERATOR SOG6292</b>	<b>19</b>
5.1 SOG6292 Outline .....	19
5.2 Option List .....	19
5.3 Segment Ports Output Specifications .....	20
5.4 SOG6292 Quick Reference .....	21
5.5 Sample Files .....	23
<b>6 ICE CONTROL SOFTWARE ICS6292</b>	<b>24</b>
6.1 ICS6292 Outline .....	24
6.2 ICS6292 Restrictions .....	24
6.3 ICS6292 Quick Reference .....	26

**CONTENTS**

<b>7 MASK DATA CHECKER MDC6292</b>	<b>29</b>
7.1 MDC6292 Outline .....	29
7.2 MDC6292 Quick Reference .....	29
<b>APPENDIX A. SIC62920 INSTRUCTION SET</b>	<b>32</b>
<b>B. SIC62920 RAM MAP</b>	<b>36</b>
<b>C. SIC62920 I/O MEMORY MAP</b>	<b>39</b>
<b>D. TROUBLESHOOTING</b>	<b>42</b>

# 1 COMPOSITION OF DEVELOPMENT SUPPORT TOOL

Here we will explain the composition of the software for the development support tools, developmental environment and how to generate the execution disk.

## 1.1 Configuration of S5U1C62920D

The below software are included in the product of the S1C62920 development support tool S5U1C62920D.

1. Development Tool Management System DMS6200 ..... Menu selection for each software / start-up software
2. Cross Assembler ASM6292 ..... Cross assembler for program preparation
3. Function Option Generator FOG6292 ..... Function option data preparation program
4. Segment Option Generator SOG6292 ..... Segment option data preparation program
5. ICE Control Software ICS6292 ..... ICE control program
6. Mask Data Checker MDC6292 ..... Mask data preparation program

## 1.2 Developmental Environment

The software product of the development support tool S5U1C62920D operates on the following host systems:

- IBM PC/AT (at least PC-DOS Ver. 2.0)

When developing the S1C62920, the above-mentioned host computer, editor, P-ROM writer, printer, etc. must be prepared by the user in addition to the development tool which is normally supported by Seiko Epson.

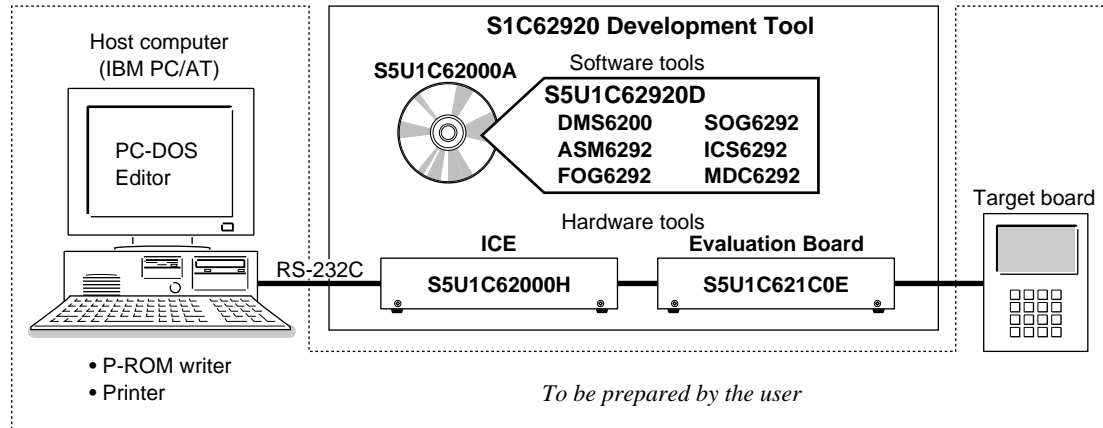

Fig. 1.2.1 System configuration

The evaluation board (S5U1C621C0E) can be used as the evaluation board for the S1C62920 by modifying the function option HEX data generated from the FOG6292. Therefore, if correct function option HEX data for the S1C62920 is not loaded in the evaluation board, the evaluation board does not identify as S1C62920 functions and does not operate correctly. Especially when the evaluation board is used for both S1C62920 and S1C621C, be aware of the function option HEX data to be loaded.

*Note* The S5U1C62920D system requires a host computer with a RAM capacity of about 140K bytes. Since the ICE (S5U1C62000H) is connected to the host computer with a RS-232C serial interface, adapter board for asynchronous communication will be required depending on the host computer used.

### 1.3 Development Flow

Figure 1.3.1 shows the development flow through the S5U1C62920D.

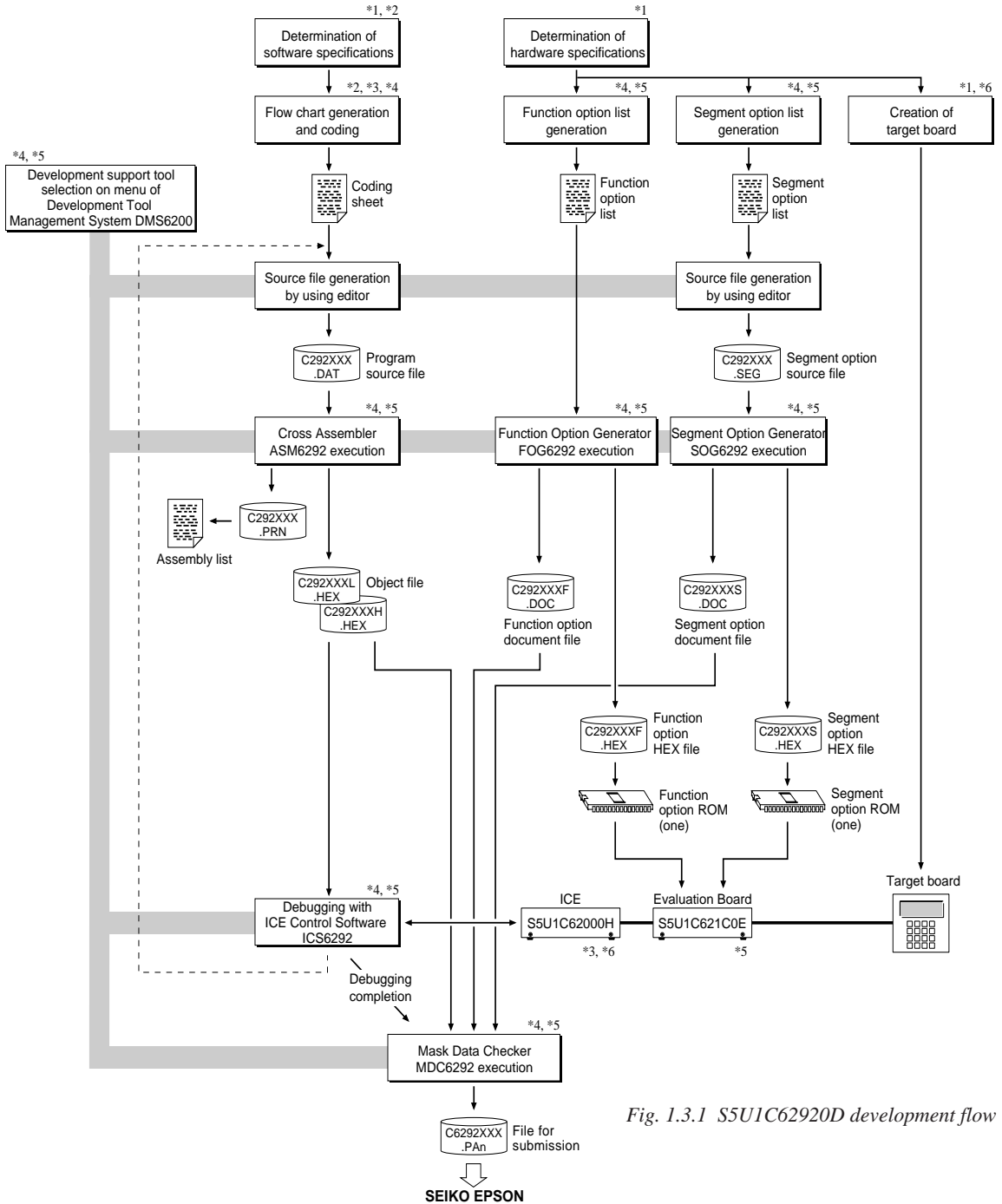

Fig. 1.3.1 S5U1C62920D development flow

#### Concerning file names

All the input-output file name for the each development support tool commonly use "C292XXX". In principle each file should be produced in this manner. Seiko Epson will designate the "XXX" for each customer.

#### Reference Manual

- \*1 S1C62920 Technical Manual (Hardware)
- \*2 S1C62920 Technical Manual (Software)
- \*3 S1C6200/6200A Core CPU Manual
- \*4 S1C62 Family Development Tool Reference Manual
- \*5 S5U1C62920D Manual (this manual)
- \*6 S5U1C621C0E Manual
- \*7 S5U1C62000H Manual

## 1.4 Installation

---

The S5U1C62920D tools are included on the CD-ROM of the S5U1C62000A (S1C60/62 Family Assembler Package), and they can be installed in your hard disk using the installer (Setup.exe) on the CD-ROM. Refer to the "S5U1C62000A Manual" for how to install the S5U1C62920D tools.

*Note* The DMS6200 configures a menu from files that are located in the current directory. Therefore, do not move the development tools from the directory in which the DMS6200 exists. To invoke an editor (DOS version) or other programs from the DMS6200, copy those executable files to the directory in which the DMS6200 exists.

# 2 DEVELOPMENT TOOL MANAGEMENT SYSTEM DMS6200

## 2.1 DMS6200 Outline

The DMS6200 (Development Tool Management System) is a software which selects the S5U1C62920D software development support tool and the program such as an editor in menu form and starts it. In this way the various software frequently executed during debugging can be effectively activated.

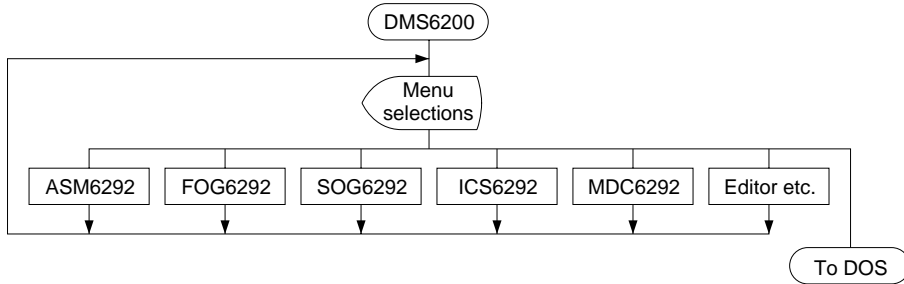

Fig. 2.1.1 DMS6200 execution flow

Refer to the "S1C62 Family Development Tool Reference Manual" for details of the operation.

## 2.2 DMS6200 Quick Reference

### ■ Starting command

Execution file: DMS6200.EXE

Starting command: DMS6200

indicates the Return key.

### ■ Display examples

```

*** E0C6200 Development tool Management System. --- Ver 1.0 ***
EEEEEEEEEE PPPPPPPP SSSSSSS 00000000 NNN NNN
EEEEEEEEEE PPPPPPPP SSS SSSS 000 000 NNNN NNN
EEE PPP PPP SSS SSS 000 000 NNNNN NNN
EEE PPP PPP SSS 000 000 NNNNNN NNN
EEEEEEEEEE PPPPPPPP SSSSSS 000 000 NNN NNN NNN
EEEEEEEEEE PPPPPPPP SSSS 000 000 NNN NNNNNN
EEE PPP SSS 000 000 NNN NNNNN
EEE PPP SSS SSS 000 000 NNN NNN
EEEEEEEEEE PPP SSS SSS 000 000 NNN NNN
EEEEEEEEEE PPP SSSSSS 00000000 NNN NNN
(C) Copyright 1991 SEIKO EPSON CORP.
STRIKE ANY KEY.
  
```

### Start message

When DMS6200 is started, the following message is displayed. For "STRIKE ANY KEY.", press any key to advance the program execution. To suspend execution, press the "CTRL" and "C" keys together: the sequence returns to the DOS command level.

```

DMS6200 Version 1.0 Copyright(C) SEIKO EPSON CORP. 1991.
1) ASM6292 .EXE
2) FOG6292 .EXE
3) ICS6292B.BAT
4) ICS6292W.EXE
5) MDC6292 .EXE
6) SOG6292 .EXE
Input Number ? [ 1 ]
  
```

### Menu screen

A list of all executable files will appear on this menu screen. Input the number of the development support tool you wish to start and then press the "RETURN" key. To return to DOS at this point, press the "ESC" key.

```

DMS6200 Version 1.0 Copyright(C) SEIKO EPSON CORP. 1991.
1) C292XXX .DAT
2) C292XXX .PRN
3) C292XXX .SEG
:
10) C6292XXX.PA0
Input Number ? [ 1 ]
Edit > [ASM6292 C292XXX ]
  
```

### Source file selection screen

To starting ASM6292, select the source file on this screen. When the source file is selected by number, the edit line enclosed in [ ] will appear; enter the option parameter if necessary. Press the "RETURN" key when input is completed. When starting, press the "RETURN" key twice particularly for the support tools which do not require source files. To return to DOS at this point, press the "ESC" key.

# 3 CROSS ASSEMBLER ASM6292

## 3.1 ASM6292 Outline

The ASM6292 cross assembler is an assembler program for generating the machine code used by the S1C62920 4-bit, single-chip microcomputers. The Cross Assembler ASM6292 will assemble the program source files which have been input by the user's editor and will generate an object file in Intel-Hex format and assembly list file. In this assembler, program modularization has been made possible through macro definition functions and programming independent of the ROM page structure has been made possible through the auto page set function. In addition, consideration has also been given to precise error checks for program capacity (ROM capacity) overflows, undefined codes and the like, and for debugging of such things as label tables for assembly list files and cross reference table supplements.

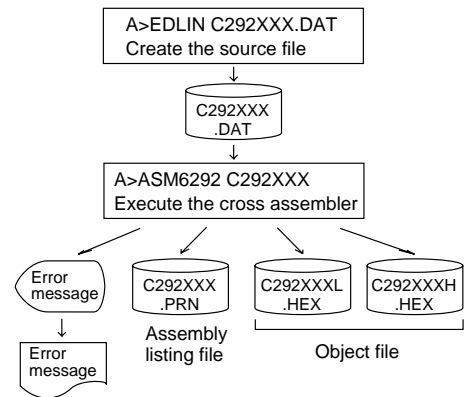

Fig. 3.1.1 ASM6292 execution flow

The format of the source file and its operating method are same as for the S1C62 Family. Refer to the "S1C62 Family Development Tool Reference Manual" for details.

## 3.2 S1C62920 Restrictions

Note the following when generating a program by the S1C62920:

### ■ ROM area

The capacity of the S1C62920 ROM is 2K steps (0000H to 07FFH).

Therefore, the specification range of the memory setting pseudo-instructions and PSET instruction is restricted.

#### Memory configuration:

Bank: Only bank 0, Page: 8 pages (0 to 07H), each 256 steps

#### Significant specification range:

ORG pseudo-instruction: 0000H to 07FFH

PAGE pseudo-instruction: 00H to 07H

BANK pseudo-instruction: Only 0H

PSET instruction: 00H to 07H

### ■ RAM area

The capacity of the S1C62920 RAM is 193 words (000H to 1FFH, 4 bits/word).

However, note the following points when programming.

(1) The following addresses become unused area. Memory access is invalid when the unused area is specified.

- 82H–90H, 93H–9FH, A1H–AFH, B1H, B3H, B5H, B7H–BFH, C0H, C2H–C5H, C7H, CBH–CFH, D7H–DFH, E0H–E7H, EBH–EFH, F2H, F5H–F7H, FAH and FDH–FFH in page 0 to 1
- 100H–15FH

(2) Since RAM is set for up to 1 page, only the subordinate 1 bit of the page section of the index register which specifies address is effective. (The 3 superordinate bits are ignored.)

**Example:**

LD	A, 2	090H is loaded into the IX register, but an unused area has been specified
LD	XP, A	so that the memory accessible with the IX register (MX) is invalid.
LD	X, 90H	

### ■ Undefined codes

The SLP instruction has not been defined in the S1C62920 instruction sets.

### 3.3 ASM6292 Quick Reference

#### Starting command and input/output files

\_ indicates a blank.

indicates the Return key.

A parameter enclosed by [ ] can be omitted.

**Execution file:** ASM6292.EXE

**Starting command:** **ASM6292\_ [drive-name:] source-file-name [.shp] \_ [-N]**

- Option:**
- .shp Specifies the file I/O drives.
  - s Specifies the drive from which the source file is to be input. (A–P, @)
  - h Specifies the drive to which the object file is to be output. (A–P, @, Z)
  - p Specifies the drive to which the assembly listing file is to be output. (A–P, @, Z)  
@: Current drive, Z: File is not generated
  - N The code (FFH) in the undefined area of program memory is not created.

**Input file:** C292XXX.DAT (Source file)

**Output file:** C292XXXL.HEX (Object file, low-order)  
C292XXXH.HEX (Object file, high-order)  
C292XXX.PRN (Assembly listing file)

#### Display example

```

*** E0C6292 CROSS ASSEMBLER. --- Ver 2.00 ***
EEEEEEEEEE P P P P P P P P S S S S S S O O O O O O O O N N N N N N N N
EEEEEEEEEE P P P P P P P P P P S S S S S S O O O O O O N N N N N N N N
EEE PPP PPP S S S S S S O O O O O O N N N N N N N N
EEE PPP PPP S S S O O O O O O N N N N N N N N
EEEEEEEEEE P P P P P P P P P P S S S S S S O O O O O O N N N N N N N N
EEEEEEEEEE P P P P P P P P S S S S S S O O O O O O N N N N N N N N
EEE PPP PPP S S S S S S O O O O O O N N N N N N N N
EEE PPP S S S S S S O O O O O O N N N N N N N N
EEEEEEEEEE PPP S S S S S S O O O O O O N N N N N N N N
EEEEEEEEEE PPP S S S S S S O O O O O O N N N N N N N N

(C) COPYRIGHT 1993 SEIKO EPSON CORP.

SOURCE FILE NAME IS " C292XXX.DAT "

THIS SOFTWARE MAKES NEXT FILES.

C292XXXH.HEX ... HIGH BYTE OBJECT FILE.
C292XXXL.HEX ... LOW BYTE OBJECT FILE.
C292XXX.PRN ... ASSEMBLY LIST FILE.

DO YOU NEED AUTO PAGE SET? (Y/N) Y ... (1)
DO YOU NEED CROSS REFERENCE TABLE? (Y/N) Y ... (2)
    
```

When ASM6292 is started, the start-up message is displayed.

At (1), select whether or not the auto-page-set function will be used.

Use ..... Y

Not use ..... N

If the assembly listing file output is specified, message (2) is displayed. At this stage, cross-reference table generation may be selected.

Generating ..... Y

Not generating ..... N

When the above operation is completed, ASM6292 assembles the source file.

To suspend execution, press the "CTRL" and "C" keys together at stage (1) or (2).

#### Operators

Arithmetic operators		Logical operators	
+a	Monadic positive	a_AND_b	Logical product
-a	Monadic negative	a_OR_b	Logical sum
a+b	Addition	a_XOR_b	Exclusive logical sum
a-b	Subtraction	NOT_a	Logical negation
a*b	Multiplication	Relational operators	
a/b	Division	a_EQ_b	True when a is equal to b
a_MOD_b	Remainder of a/b	a_NE_b	True when a is not equal to b
a_SHL_b	Shifts a b bits to the left	a_LT_b	True when a is less than b
a_SHR_b	Shifts a b bits to the right	a_LE_b	True when a is less than or equal to b
HIGH_a	Separates the high-order eight bits from a	a_GT_b	True when a is greater than b
LOW_a	Separates the low-order eight bits from a	a_GE_b	True when a is greater than or equal to b

## ■ Pseudo-instructions

Pseudo-instruction	Meaning	Example of Use
EQU (Equation)	To allocate data to label	ABC EQU 9 BCD EQU ABC+1
SET (Set)	To allocate data to label (data can be changed)	ABC SET 0001H ABC SET 0002H
DW (Define Word)	To define ROM data	ABC DW 'AB' BCD DW 0FFBH
ORG (Origin)	To define location counter	ORG 100H ORG 256
PAGE (Page)	To define boundary of page	PAGE 1H PAGE 3
SECTION (Section)	To define boundary of section	SECTION
END (End)	To terminate assembly	END
MACRO (Macro)	To define macro	CHECK MACRO DATA LOCAL LOOP
LOCAL (Local)	To make local specification of label during macro definition	LOOP CP MX, DATA JP NZ, LOOP ENDM
ENDM (End Macro)	To end macro definition	CHECK 1

## ■ Error messages

Error message	Explanation
S (Syntax Error)	An unrecoverable syntax error was encountered.
U (Undefined Error)	The label or symbol of the operand has not been defined.
M (Missing Label)	The label field has been omitted.
O (Operand Error)	A syntax error was encountered in the operand, or the operand could not be evaluated.
P (Phase Error)	The same label or symbol was defined more than once.
R (Range Error)	<ul style="list-style-type: none"> <li>• A statement exceeded a page boundary although its location was not specified.</li> <li>• The location counter value exceeded the upper limit of the program memory, or a location exceeding the upper limit was specified.</li> <li>• A value greater than that which the number of significant digits of the operand will accommodate was specified.</li> </ul>
! (Warning)	<ul style="list-style-type: none"> <li>• Memory areas overlapped because of a "PAGE" or "ORG" pseudo-instruction or both.</li> </ul>
FILE NAME ERROR	The source file name was longer than 8 characters.
FILE NOT PRESENT	The specified source file was not found.
DIRECTORY FULL	No space was left in the directory of the specified disk.
FATAL DISK WRITE ERROR	The file could not be written to the disk.
LABEL TABLE OVERFLOW	The number of defined labels and symbols exceeded the label table capacity (4000).
CROSS REFERENCE TABLE OVERFLOW	The label/symbol reference count exceeded the cross-reference table capacity (only when the cross-reference table is generated).

# 4 FUNCTION OPTION GENERATOR FOG6292

## 4.1 FOG6292 Outline

With the 4-bit single-chip S1C62920 microcomputers, the customer may select five hardware options. By modifying the mask patterns of the S1C62920 according to the selected options, the system can be customized to meet the specifications of the target system.

The Function Option Generator FOG6292 is a software tool for generating data files used to generate mask patterns. It enables the customer to interactively select and specify pertinent items for each hardware option. From the data file created with FOG6292, the S1C62920 mask pattern is automatically generated by a general purpose computer.

The HEX file for the evaluation board (S5U1C621C0E) hardware option ROM is simultaneously generated with the data file.

(The evaluation board can be used as the evaluation board for the S1C62920 by modifying the function option HEX data generated from the FOG6292.)

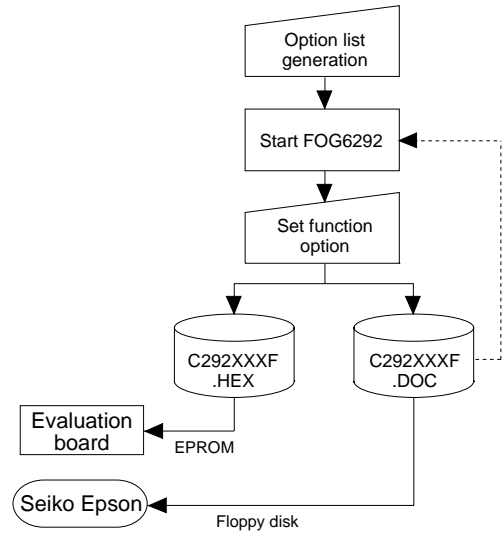

Fig. 4.1.1 FOG6292 execution flow

The operating method is same as for the S1C62 Family. Refer to the "S1C62 Family Development Tool Reference Manual" for details.

## 4.2 S1C62920 Option List

Multiple specifications are available in each option item as indicated in the Option List. Using "4.3 Option Specifications and Selection Message" as reference, select the specifications that meet the target system. Be sure to record the specifications for unused ports too, according to the instructions provided.

### 1. OSC3 OSCILLATOR

- 1. CR
- 2. Ceramic

### 2. INTERRUPT (K00–K03)

- |             |                                 |                                     |
|-------------|---------------------------------|-------------------------------------|
| • K00 ..... | <input type="checkbox"/> 1. Use | <input type="checkbox"/> 2. Not Use |
| • K01 ..... | <input type="checkbox"/> 1. Use | <input type="checkbox"/> 2. Not Use |
| • K02 ..... | <input type="checkbox"/> 1. Use | <input type="checkbox"/> 2. Not Use |
| • K03 ..... | <input type="checkbox"/> 1. Use | <input type="checkbox"/> 2. Not Use |

### 3. INPUT PORT PULL-UP RESISTOR

- |             |   |   |
|-------------|---|---|
| • K00 ..... | <input type="checkbox"/> 1. With Resistor | <input type="checkbox"/> 2. Gate Direct |
| • K01 ..... | <input type="checkbox"/> 1. With Resistor | <input type="checkbox"/> 2. Gate Direct |
| • K02 ..... | <input type="checkbox"/> 1. With Resistor | <input type="checkbox"/> 2. Gate Direct |
| • K03 ..... | <input type="checkbox"/> 1. With Resistor | <input type="checkbox"/> 2. Gate Direct |

### 4. R02 OUTPUT SPECIFICATION

- R02 .....
- |                                  |
|----------------------------------|
| <input type="checkbox"/> 1. D.C. |
| <input type="checkbox"/> 2. FOUT |

### FOUT OR SIF FREQUENCY

- FREQ. ....
- |                                  |      |
|----------------------------------|------|
| <input type="checkbox"/> 1. 1/64 | OSC1 |
| <input type="checkbox"/> 2. 1/8  | OSC1 |
| <input type="checkbox"/> 3.      | OSC1 |
| <input type="checkbox"/> 4.      | OSC3 |

**5. R03 OUTPUT SPECIFICATION**

- R03 .....  1. D.C.
- 2. BZ 1/16 OSC1
- 3. BZ 1/8 OSC1

**6. OUTPUT PORT OUTPUT SPECIFICATION**

- |             |   |  |
|-------------|---|--|
| • R00 ..... | <input type="checkbox"/> 1. Complementary | <input type="checkbox"/> 2. Nch Open Drain |
| • R01 ..... | <input type="checkbox"/> 1. Complementary | <input type="checkbox"/> 2. Nch Open Drain |
| • R02 ..... | <input type="checkbox"/> 1. Complementary | <input type="checkbox"/> 2. Nch Open Drain |
| • R03 ..... | <input type="checkbox"/> 1. Complementary | <input type="checkbox"/> 2. Nch Open Drain |

**7. I/O PORT PULL-UP RESISTOR**

- |             |   |   |
|-------------|---|---|
| • P00 ..... | <input type="checkbox"/> 1. With Resistor | <input type="checkbox"/> 2. Gate Direct |
| • P01 ..... | <input type="checkbox"/> 1. With Resistor | <input type="checkbox"/> 2. Gate Direct |
| • P02 ..... | <input type="checkbox"/> 1. With Resistor | <input type="checkbox"/> 2. Gate Direct |
| • P03 ..... | <input type="checkbox"/> 1. With Resistor | <input type="checkbox"/> 2. Gate Direct |
| • P10 ..... | <input type="checkbox"/> 1. With Resistor | <input type="checkbox"/> 2. Gate Direct |
| • P11 ..... | <input type="checkbox"/> 1. With Resistor | <input type="checkbox"/> 2. Gate Direct |
| • P12 ..... | <input type="checkbox"/> 1. With Resistor | <input type="checkbox"/> 2. Gate Direct |
| • P13 ..... | <input type="checkbox"/> 1. With Resistor | <input type="checkbox"/> 2. Gate Direct |

**8. SVD VOLTAGE**

- 1. 2.4[V]
- 2. 2.5[V]
- 3. 2.6[V]
- 4. 2.7[V]

**9. LCD DRIVE DUTY**

- 1. 1/2
- 2. 1/3
- 3. 1/4

### 4.3 Option Specifications and Selection Message

Screen that can be selected as function options set on the S1C62920 are shown below, and their specifications are also described.

#### 1 OSC3 oscillator

```

*** OPTION NO.1 ***

--- OSC3 OSCILLATOR ---
                1. CR
                2. CERAMIC

PLEASE SELECT NO.(1) ? 1 [ ]

                1. CR  SELECTED
    
```

Select the OSC3 system clock to be used for the S1C62920. The OSC3 oscillation circuit generates the system clock when operating the CPU in high-speed. Either ceramic oscillation or CR oscillation can be selected for the oscillation circuit that uses the OSC3 and OSC4 terminals. When ceramic oscillation is selected, ceramic oscillator, gate capacitor and drain capacitor should be connected between the OSC3 and the OSC4 terminals. When CR oscillation is selected, resistor only need be connected between the terminals. The configuration of the OSC3 oscillation circuit is shown in Figure 4.3.1.

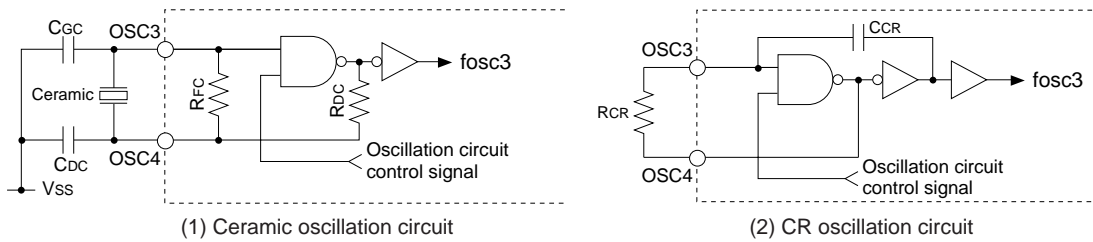

Fig. 4.3.1 OSC3 oscillation circuit

#### 2 Interrupt (K00–K03)

```

*** OPTION NO.2 ***

--- INTERRUPT (K00–K03) ---
    K00          1. USE
                2. NOT USE

PLEASE SELECT NO.(1) ? 1 [ ]

    K01          1. USE
                2. NOT USE

PLEASE SELECT NO.(1) ? 1 [ ]

    K02          1. USE
                2. NOT USE

PLEASE SELECT NO.(1) ? 1 [ ]

    K03          1. USE
                2. NOT USE

PLEASE SELECT NO.(1) ? 1 [ ]

    K00          1. USE  SELECTED
    K01          1. USE  SELECTED
    K02          1. USE  SELECTED
    K03          1. USE  SELECTED
    
```

Select whether the input port interrupt function that generates interrupt according to the input status will be used or not. It should be selected for each bit of K00–K03. When "NOT USE" is selected, the interrupt is masked even if the input signal to the input port changes to any other status. The configuration of the input interrupt circuit is shown in Figure 4.3.2.

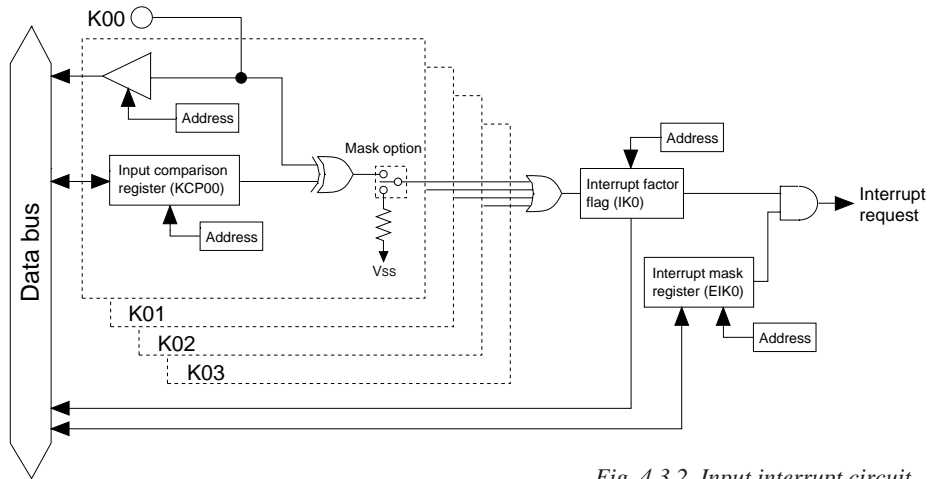

Fig. 4.3.2 Input interrupt circuit

### 3 Input port pull-up resistor

```

*** OPTION NO.3 ***
--- INPUT PORT PULL-UP RESISTOR ---
    K00          1. WITH RESISTOR
                 2. GATE DIRECT
PLEASE SELECT NO.(1) ? 1 [x]

    K01          1. WITH RESISTOR
                 2. GATE DIRECT
PLEASE SELECT NO.(1) ? 1 [x]

    K02          1. WITH RESISTOR
                 2. GATE DIRECT
PLEASE SELECT NO.(1) ? 1 [x]

    K03          1. WITH RESISTOR
                 2. GATE DIRECT
PLEASE SELECT NO.(1) ? 1 [x]

    K00          1. WITH RESISTOR  SELECTED
    K01          1. WITH RESISTOR  SELECTED
    K02          1. WITH RESISTOR  SELECTED
    K03          1. WITH RESISTOR  SELECTED
    
```

Select whether each input port (K00–K03) will be supplemented with a pull-up resistor or not. When "GATE DIRECT" is selected, see to it that an entry floating state does not occur. Moreover, when "WITH RESISTOR" has been selected and when input ports are changed from low level (VSS) to high level (VDD) with pull-up resistor, the rise of the waveform is delayed on account of the time constant of the pull-up resistor and input gate capacitance. Hence, when fetching input ports, be sure to wait an appropriate amount of time with the program. For unused ports, select "WITH RESISTOR". The configuration of the pull-up resistor circuit is shown in Figure 4.3.3.

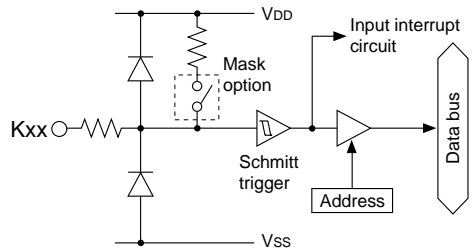

Fig. 4.3.3 Configuration of pull-up resistor circuit

### 4 R02 output specification

```

*** OPTION NO.4 ***

--- R02 OUTPUT SPEC. ---
    R02          1. D.C.
                  2. FOUT

PLEASE SELECT NO.(1) ? 1 

--- FOUT OR SIF FREQ. ---
    FREQ.        1. 1/64 OSC1
                  2. 1/8  OSC1
                  3.      OSC1
                  4.      OSC3

PLEASE SELECT NO.(1) ? 1 

    R02          1. D.C.  SELECTED
    FREQ.        1. 1/64 OSC1 SELECTED
    
```

For the output specification of the R02 port, select either "DC" output or "FOUT" output. When "DC" output is selected, the R02 port functions the same as the R00 and R01 ports. When "FOUT" output is selected, the clock is output from the R02 port with the frequency selected from the following selection items. "FOUT" output is controlled using the R02 register (A0H•D2); low level is output when the register is "0" and the "FOUT" signal is output when the register is "1". In this option, frequency for "FOUT" or "SIF" should be selected. When "FOUT" output is selected for the R02 output specification, the selected frequency is used for the "FOUT" signal. The selected frequency is also used for the SIF (serial interface) clock to send/receive data when the SIF is in the master mode. Because the selected frequency is used for the SIF even when "DC" output is selected for the R02 output specification, a frequency must be selected. The configuration of the R02 port is shown in Figure 4.3.4.

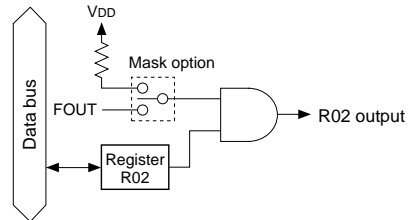

Fig. 4.3.4 Configuration of R02 port

### 5 R03 output specification

```

*** OPTION NO.5 ***

--- R03 OUTPUT SPEC. ---
    R03          1. D.C.
                  2. BZ 1/16 OSC1
                  3. BZ 1/8  OSC1

PLEASE SELECT NO.(1) ? 1 

    R03          1. D.C.  SELECTED
    
```

Select the output specification of the R03 port from the "DC" output, "BZ 1/16 OSC1" or "BZ 1/8 OSC1". When "DC" output is selected, the R03 port functions the same as the R00 and R01 ports. When "BZ 1/16 OSC1" or "BZ 1/8 OSC1" is selected, the buzzer drive waveform with the selected frequency is output from the R03 port. "BZ" output is controlled using the R03 register (A0H•D3); low level is output when the register is "0" and the "BZ" signal is output when the register is "1". The configuration of the R03 port is shown in Figure 4.3.5.

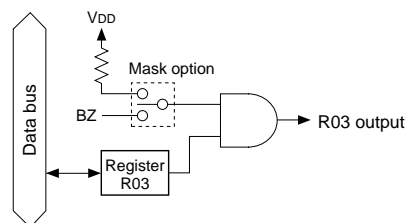

Fig. 4.3.5 Configuration of R03 port

## 6 Output port output specification

```

*** OPTION NO.6 ***
--- OUTPUT PORT OUTPUT SPEC. ---
R00          1. COMPLEMENTARY
              2. NCH OPEN DRAIN
PLEASE SELECT NO.(1) ? 1 [x]

R01          1. COMPLEMENTARY
              2. NCH OPEN DRAIN
PLEASE SELECT NO.(1) ? 1 [x]

R02          1. COMPLEMENTARY
              2. NCH OPEN DRAIN
PLEASE SELECT NO.(1) ? 1 [x]

R03          1. COMPLEMENTARY
              2. NCH OPEN DRAIN
PLEASE SELECT NO.(1) ? 1 [x]

R00          1. COMPLEMENTARY  SELECTED
R01          1. COMPLEMENTARY  SELECTED
R02          1. COMPLEMENTARY  SELECTED
R03          1. COMPLEMENTARY  SELECTED
    
```

Select the output specification of each output port (R00–R03). Either "COMPLEMENTARY" output or "Nch OPEN DRAIN" output can be selected. When the output port is used as a common output for key matrix, select "Nch OPEN DRAIN" output. For unused output ports, select "COMPLEMENTARY" output. The configuration of the output circuit is shown in Figure 4.3.6.

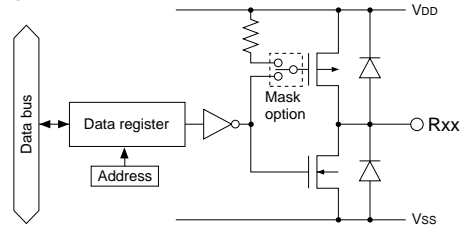

Fig. 4.3.6 Configuration of output circuit

## 7 I/O port pull-up resistor

```

*** OPTION NO.7 ***
--- I/O PORT PULL-UP RESISTOR ---
P00          1. WITH RESISTOR
              2. GATE DIRECT
PLEASE SELECT NO.(1) ? 1 [x]

P01          1. WITH RESISTOR
              2. GATE DIRECT
PLEASE SELECT NO.(1) ? 1 [x]

P02          1. WITH RESISTOR
              2. GATE DIRECT
PLEASE SELECT NO.(1) ? 1 [x]

P03          1. WITH RESISTOR
              2. GATE DIRECT
PLEASE SELECT NO.(1) ? 1 [x]

P10          1. WITH RESISTOR
              2. GATE DIRECT
PLEASE SELECT NO.(1) ? 1 [x]

P11          1. WITH RESISTOR
              2. GATE DIRECT
PLEASE SELECT NO.(1) ? 1 [x]

P12          1. WITH RESISTOR
              2. GATE DIRECT
PLEASE SELECT NO.(1) ? 1 [x]

P13          1. WITH RESISTOR
              2. GATE DIRECT
PLEASE SELECT NO.(1) ? 1 [x]

P00          1. WITH RESISTOR  SELECTED
P01          1. WITH RESISTOR  SELECTED
P02          1. WITH RESISTOR  SELECTED
P03          1. WITH RESISTOR  SELECTED
P10          1. WITH RESISTOR  SELECTED
P11          1. WITH RESISTOR  SELECTED
P12          1. WITH RESISTOR  SELECTED
P13          1. WITH RESISTOR  SELECTED
    
```

Select whether each I/O port (P00–P03, P10–P13) will be supplemented with a pull-up resistor that functions when the I/O port is in the input mode or not.

When "GATE DIRECT" is selected, see to it that an entry floating state does not occur. Moreover, when "WITH RESISTOR" has been selected and when input terminals are changed from low level (VSS) to high level (VDD) with pull-up resistor, the rise of the waveform is delayed on account of the time constant of the pull-up resistor and input gate capacitance. Hence, when fetching input signals, be sure to wait an appropriate amount of time with the program.

For unused ports, select "WITH RESISTOR". However, when the I/O port is in output mode, the port is not pulled up even if "WITH RESISTOR" is selected.

The configuration of the I/O port is shown in Figure 4.3.7.

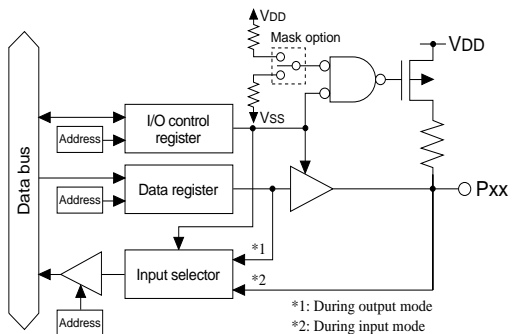

Fig. 4.3.7 Configuration of I/O port

**8 SVD (Supply Voltage Detection circuit) voltage**

```

*** OPTION NO.8 ***
--- S.V.D VOLTAGE ---
                1. 2.4[V]
                2. 2.5[V]
                3. 2.6[V]
                4. 2.7[V]

PLEASE SELECT NO.(1) ? 1 

                1. 2.4[V]  SELECTED

```

Select criteria voltage for supply voltage detection.

**9 LCD drive duty**

```

*** OPTION NO.9 ***
--- LCD DRIVE DUTY ---
                1. 1/2
                2. 1/3
                3. 1/4

PLEASE SELECT NO.(1) ? 1 

                1. 1/2  SELECTED

```

Select drive duty for LCD panel from 1/2 duty, 1/3 duty or 1/4 duty.

The LCD panel is driven with the selected duty.

## 4.4 FOG6292 Quick Reference

### ■ Starting command and input/output files

**Execution file:** FOG6292.EXE

**Starting command:** FOG6292   indicates the Return key.

**Input file:** C292XXXF.DOC (Function option document file, when modifying)

**Output file:** C292XXXF.DOC (Function option document file)  
C292XXXF.HEX (Function option HEX file)

### ■ Display example

```

*** E0C6292 FUNCTION OPTION GENERATOR. --- Ver 3.14 ***
EEEEEEEEEE PPPPPPPP SSSSSSS 00000000 NNN NNN
EEEEEEEEEE PPPPPPPP SSS SSSS 000 000 NNNN NNN
EEE PPP PPP SSS SSS 000 000 NNNNN NNN
EEE PPP PPP SSS 000 000 NNNNNN NNN
EEEEEEEEEE PPPPPPPP SSSSSS 000 000 NNN NNN NNN
EEEEEEEEEE PPPPPPPP SSSS 000 000 NNN NNNNN
EEE PPP SSS 000 000 NNN NNNNN
EEE PPP SSS SSS 000 000 NNN NNNN
EEEEEEEEEE PPP SSS SSS 000 000 NNN NNN
EEEEEEEEEE PPP SSSSSS 00000000 NNN NN

(C) COPYRIGHT 1994 SEIKO EPSON CORP.

THIS SOFTWARE MAKES NEXT FILES.

C292XXXF.HEX ... FUNCTION OPTION HEX FILE.
C292XXXF.DOC ... FUNCTION OPTION DOCUMENT FILE.

STRIKE ANY KEY.

```

#### Start-up message

When FOG6292 is started, the start-up message is displayed.

For "STRIKE ANY KEY.", press any key to advance the program execution.

To suspend execution, press the "CTRL" and "C" keys together: the sequence returns to the DOS command level.

```

*** E0C6292 USER'S OPTION SETTING. --- Ver 3.14 ***
CURRENT DATE IS 94/01/19
PLEASE INPUT NEW DATE : 94/01/20 

```

#### Date input

Enter the 2-digit year, month, and day of the month by delimiting them with a slash ("/"). When not modifying the date, press the RETURN key "" to continue.

```

*** OPERATION SELECT MENU ***
1. INPUT NEW FILE
2. EDIT FILE
3. RETURN TO DOS

PLEASE SELECT NO.?

```

#### Operation selection menu

Enter a number from 1 to 3 to select a subsequent operation.

1. To set new function options.
2. To modify the document file.
3. To terminate FOG6292.

```

*** OPERATION SELECT MENU ***
1. INPUT NEW FILE
2. EDIT FILE
3. RETURN TO DOS

PLEASE SELECT NO.? 1 
PLEASE INPUT FILE NAME? C2920A0  ..(1)
PLEASE INPUT USER'S NAME? SEIKO EPSON CORP.  ..(2)
PLEASE INPUT ANY COMMENT
(ONE LINE IS 50 CHR)? TOKYO DESIGN CENTER  ..(3)
? 421-8 HINO HINO-SHI TOKYO 191 JAPAN 
? TEL 0425-84-2551 
? FAX 0425-84-8512 
? 

```

#### Setting new function options

Select "1" on the operation selection menu.

- (1) Enter the file name.
- (2) Enter the customer's company name.
- (3) Enter any comment.  
(Within 50 characters x 10 lines)

Next, start function option setting from option No. 1.

```

PLEASE INPUT FILE NAME? C2920A0 
EXISTS OVERWRITE(Y/N)? N 
PLEASE INPUT FILE NAME? C2920B0 
PLEASE INPUT USER'S NAME?

```

In case a function option document file with the same name as the file name specified in the current drive exists, the user is asked whether overwriting is desired. Enter "Y" or "N" accordingly.

```

*** OPERATION SELECT MENU ***

    1. INPUT NEW FILE
    2. EDIT FILE
    3. RETURN TO DOS

PLEASE SELECT NO.? 2[ ]

*** SOURCE FILE(S) ***

C2920A0          C2920B0          C2920C0          ..(1)

PLEASE INPUT FILE NAME? C2920A0[ ] ..(2)
PLEASE INPUT USER'S NAME? [ ] ..(3)
PLEASE INPUT ANY COMMENT
(ONE LINE IS 50 CHR)? [ ] ..(4)
PLEASE INPUT EDIT NO.? 4[ ] ..(5)
:
(Modifying function option settings)
:
PLEASE INPUT EDIT NO.? E[ ]

```

In step (1), if no modifiable source exists, the following message is displayed and the sequence returns to the operation selection menu.

```

*** SOURCE FILE(S) ***

FUNCTION OPTION DOCUMENT FILE IS NOT FOUND.

```

In step (2), if the function option document file is not in the current drive, the following message is displayed, prompting entry of other file name.

```

PLEASE INPUT FILE NAME? C2920N0[ ]
FUNCTION OPTION DOCUMENT FILE IS NOT FOUND.
PLEASE INPUT FILE NAME?

```

In addition, if specified file format is different (such as document file for the other model), the following message is displayed and FOG6292 is terminated.

```

BAD FUNCTION OPTION DOCUMENT FILE.

```

```

*** OPTION NO.1 ***

--- OSC3 OSCILLATOR ---

    1. CR
    2. CERAMIC

PLEASE SELECT NO.(1) ? 1[ ]

    1. CR  SELECTED

```

```

END OF OPTION SETTING.
DO YOU MAKE HEX FILE (Y/N) ? Y[ ] ..(1)

*** OPTION EPROM SELECT MENU ***

    1. 27C64
    2. 27C128
    3. 27C256
    4. 27C512

PLEASE SELECT NO.? 2[ ] ..(2)

    2. 27C128  SELECTED

MAKING FILE(S) IS COMPLETED.

*** OPERATION SELECT MENU ***

    1. INPUT NEW FILE
    2. EDIT FILE
    3. RETURN TO DOS

PLEASE SELECT NO.?

```

### Modifying function option settings

Select "2" on the operation selection menu.

- (1) Will display the files on the current drive.
- (2) Enter the file name.
- (3) Enter the customer's company name.
- (4) Enter any comment.

Previously entered data can be used by pressing the RETURN key "[ ]" at (3) and (4).

- (5) Enter the number of the function option to be modified. When selection of one option is complete, the system prompts entry of another function option number. Repeat selection until all options to be modified are selected. Enter "E[ ]" to end option setting. Then, move to the confirmation procedure for HEX file generation.

### Option selection

The selections for each option correspond one to one to the option list. Enter the selection number.

The value in parentheses ( ) indicates the default value, and is set when only the RETURN key "[ ]" is pressed.

In return, the confirmation is displayed.

When you wish to modify previously set function options in the new setting process, enter "B[ ]" to return 1 step back to the previous function option setting operation.

### EPROM selection

When setting function options setting is completed, the following message is output to ask the operator whether to generate the HEX file.

- (1) When debugging the program with the evaluation board, HEX file is needed, so enter "Y[ ]". If "N[ ]" is entered, no HEX file is generated and only document file is generated.
- (2) For the option ROM selection menu displayed when "Y[ ]" is entered in Step (1), select the EPROM to be used for setting evaluation board options.

When a series of operations are complete, the sequence returns to the operation selection menu.

## 4.5 Sample File

### ■ Example of function option document file

```

* E0C6292 FUNCTION OPTION DOCUMENT V 3.14
*
* FILE NAME      C292TS1F.DOC
* USER'S NAME    SEIKO EPSON CORP.
* INPUT DATE     1994/01/19
*
*
* OPTION NO.1
* < OSC3 OSCILLATOR >
*
*                CR ----- SELECTED
OPT0101 01
*
* OPTION NO.2
* < INTERRUPT (K00-K03) >
*   K00          USE ----- SELECTED
*   K01          USE ----- SELECTED
*   K02          USE ----- SELECTED
*   K03          USE ----- SELECTED
OPT0201 01
OPT0202 01
OPT0203 01
OPT0204 01
*
* OPTION NO.3
* < INPUT PORT PULL-UP RESISTOR >
*   K00          WITH RESISTOR ----- SELECTED
*   K01          WITH RESISTOR ----- SELECTED
*   K02          WITH RESISTOR ----- SELECTED
*   K03          WITH RESISTOR ----- SELECTED
OPT0301 01
OPT0302 01
OPT0303 01
OPT0304 01
*
* OPTION NO.4
* < R02 OUTPUT SPEC. >
*   R02          D.C. ----- SELECTED
* < FOUT OR SIF FERQ. >
*   FERQ.       1/64 OSC1 ----- SELECTED
OPT0401 01
OPT0402 01
*
* OPTION NO.5
* < R03 OUTPUT SPEC. >
*   R03          D.C. ----- SELECTED
OPT0501 01
*
* OPTION NO.6
* < OUTPUT PORT OUTPUT SPEC. >
*   R00          COMPLEMENTARY ----- SELECTED
*   R01          COMPLEMENTARY ----- SELECTED
*   R02          COMPLEMENTARY ----- SELECTED
*   R03          COMPLEMENTARY ----- SELECTED

```

#### 4 FUNCTION OPTION GENERATOR FOG6292

```
OPT0601 01
OPT0602 01
OPT0603 01
OPT0604 01
*
* OPTION NO.7
* < I/O PORT OUTPUT PULL-UP RESISTOR >
*   P00          WITH RESISTOR  -----  SELECTED
*   P01          WITH RESISTOR  -----  SELECTED
*   P02          WITH RESISTOR  -----  SELECTED
*   P03          WITH RESISTOR  -----  SELECTED
*   P10          WITH RESISTOR  -----  SELECTED
*   P11          WITH RESISTOR  -----  SELECTED
*   P12          WITH RESISTOR  -----  SELECTED
*   P13          WITH RESISTOR  -----  SELECTED
OPT0701 01
OPT0702 01
OPT0703 01
OPT0704 01
OPT0705 01
OPT0706 01
OPT0707 01
OPT0708 01
*
* OPTION NO.8
* < S.V.D VOLTAGE >
*           2.4[V] -----  SELECTED
OPT0801 01
*
* OPTION NO.9
* < LCD DRIVE DUTY >
*           1/2 -----  SELECTED
OPT0901 01
*
*
* SEIKO EPSON'S AREA
*
*
* OPTION NO.10
OPT1001 01
*
* OPTION NO.11
OPT1101 01
\\END
```

*Note* End mark "~~¥~~END" may be used instead of "\\END" depending on the PC used. (The code of \ and ¥ is 5CH.)

# 5 SEGMENT OPTION GENERATOR SOG6292

## 5.1 SOG6292 Outline

With the 4-bit single-chip S1C62920 microcomputers, the customer may select the LCD segment options. By modifying the mask patterns of the S1C62920 according to the selected options, the system can be customized to meet the specifications of the target system. The Segment Option Generator SOG6292 is a software tool for generating data file used to generate mask patterns. From the data file created with SOG6292, the S1C62920 mask pattern is automatically generated by a general purpose computer. The HEX file for the evaluation board (S5U1C621C0E) segment option ROM is simultaneously generated with the data file.

(The evaluation board can be used as the evaluation board for the S1C62920 by modifying the function option HEX data generated from the FOG6292.)

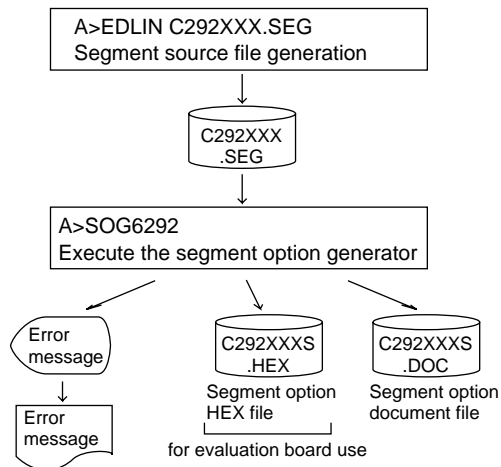

Fig. 5.1.1 SOG6292 execution flow

☞ The operating method is same as for the S1C62 Family. Refer to the "S1C62 Family Development Tool Reference Manual" for details.

## 5.2 Option List

TERMINAL NAME	ADDRESS												OUTPUT SPECIFICATION	
	COM0			COM1			COM2			COM3				
	H	L	D	H	L	D	H	L	D	H	L	D		
SEG0														SEG output
SEG1														DC output <input type="checkbox"/> C <input type="checkbox"/> N
SEG2														SEG output
SEG3														DC output <input type="checkbox"/> C <input type="checkbox"/> N
SEG4														SEG output
SEG5														DC output <input type="checkbox"/> C <input type="checkbox"/> N
SEG6														SEG output
SEG7														DC output <input type="checkbox"/> C <input type="checkbox"/> N
SEG8														SEG output
SEG9														DC output <input type="checkbox"/> C <input type="checkbox"/> N
SEG10														SEG output
SEG11														DC output <input type="checkbox"/> C <input type="checkbox"/> N
SEG12														SEG output
SEG13														DC output <input type="checkbox"/> C <input type="checkbox"/> N
SEG14														SEG output
SEG15														DC output <input type="checkbox"/> C <input type="checkbox"/> N
SEG16														SEG output
SEG17														DC output <input type="checkbox"/> C <input type="checkbox"/> N
SEG18														SEG output
SEG19														DC output <input type="checkbox"/> C <input type="checkbox"/> N
SEG20														SEG output
SEG21														DC output <input type="checkbox"/> C <input type="checkbox"/> N
Legend:	<ADDRESS>												<OUTPUT SPECIFICATION>	
	H: High order address (6 or 7)												C: Complementary output	
	L: Low order address (0-F)												N: Nch open drain output	
	D: Data bit (0-3)													

- Note
1. Even if there are unused areas, set "---" (hyphens) such that there are no blank columns.
  2. When DC output is selected, the display memory of the COM0 column becomes effective.

### 5.3 Segment Ports Output Specifications

For the output specification of the segment output ports SEG0–SEG21, segment output and DC output can be selected in units of two terminals. When used for liquid crystal panel drives, select segment output; when used as regular output port, select DC output. When DC output is selected, either complementary output or Nch open drain output may further be selected.

However, for segment output ports that will not be used, select segment output.

Refer to the "S1C62 Family Development Tool Reference Manual" for the segment option source file creation.

#### ■ When segment output is selected

The segment output port has a segment decoder built-in, and the data bit of the optional address in the display memory area (160H–17FH) can be allocated to the optional segment. With this, up to 88 segments (66 or 44 segments when 1/3 or 1/2 duty is selected, respectively) of liquid crystal panel could be driven.

The display memory may be allocated only one segment and multiple setting is not possible.

The allocated segment displays when the bit for this display memory is set to "1", and goes out when bit is set to "0".

Segment allocation is set to H for high address (6 or 7), to L for low address (0–F), and to D for data bit (0–3) and are recorded in their respective column in the option list. For segment ports that will not be used, write "---" (hyphen) in the H, L, and D columns of COM0–COM3.

Examples

- When 1/4 duty is selected
 

0	600	601	602	603	S
1	610	611	612	613	S
- When 1/3 duty is selected
 

0	600	601	602	---	S
1	610	611	612	---	S

#### ■ When DC output is selected

The DC output can be selected in units of two terminals and up to 22 terminals may be allocated for DC output. Also, either complementary output or Nch open drain output is likewise selected in units of two terminals. When the bit for the selected display memory is set to "1", the segment output port goes high (VDD), and goes low (VSS) when set to "0". Segment allocation is the same as when segment output is selected but for the while the display memory allocated to COM1–COM3 becomes ineffective. Write three hyphens ("---") in the COM1–COM3 columns in the option list.

Example

- When complementary output is set to SEG18 and SEG19, and Nch open drain output is set to SEG20 and SEG21.
 

18	720	---	---	---	C
19	730	---	---	---	C
20	740	---	---	---	N
21	750	---	---	---	N

## 5.4 SOG6292 Quick Reference

### ■ Starting command and input/output files

**Execution file:** SOG6292.EXE

\_ indicates a blank.

**Starting command:** SOG6292\_ [-H]

indicates the Return key.

A parameter enclosed by [ ] can be omitted.

**Option:** -H: Specifies the segment option document file for input file of SOG6292.

**Input file:** C292XXX.SEG (Segment option source file)  
C292XXXS.DOC (Segment option document file, when -H option use)

**Output file:** C292XXXS.DOC (Segment option document file)  
C292XXXS.HEX (Segment option HEX file)

### ■ Display example

```

*** E0C6292 SEGMENT OPTION GENERATOR. --- Ver 3.21 ***
EEEEEEEEEE P P P P P P P P S S S S S S S S O O O O O O O O N N N N N N
EEEEEEEEEE P P P P P P P P P P S S S S S S S S O O O O O O N N N N N N
EEE EEE P P P P P P P P S S S S S S S S O O O O O O N N N N N N
EEE EEE P P P P P P P P S S S S S S S S O O O O O O N N N N N N
EEEEEEEEEE P P P P P P P P P P S S S S S S S S O O O O O O N N N N N N
EEEEEEEEEE P P P P P P P P S S S S S S S S O O O O O O N N N N N N
EEE EEE P P P P P P P P S S S S S S S S O O O O O O N N N N N N
EEE EEE P P P P P P P P S S S S S S S S O O O O O O N N N N N N
EEEEEEEEEE P P P P P P P P S S S S S S S S O O O O O O N N N N N N
EEEEEEEEEE P P P P P P P P S S S S S S S S O O O O O O N N N N N N

(C) COPYRIGHT 1993 SEIKO EPSON CORP.

SEGMENT OPTION SOURCE FILE NAME IS " C292XXX.SEG "

THIS SOFTWARE MAKES NEXT FILES.

C292XXXS.HEX ... SEGMENT OPTION HEX FILE.
C292XXXS.DOC ... SEGMENT OPTION DOCUMENT FILE.

STRIKE ANY KEY.

```

#### Start-up message

When SOG6292 is started, the start-up message is displayed.

For "STRIKE ANY KEY.", press any key to advance the program execution.

To suspend execution, press the "CTRL" and "C" keys together: the sequence returns to the DOS command level.

```

*** E0C6292 USER'S OPTION SETTING. --- Ver 3.21 ***
CURRENT DATE IS 94/01/19
PLEASE INPUT NEW DATE : 94/01/20 

```

#### Date input

Enter the 2-digit year, month, and day of the month by delimiting them with a slash ("/"). When not modifying the date, press the RETURN key "" to continue.

```

*** SOURCE FILE(S) ***
C2920A0 C2920B0 C2920C0 ..(1)
PLEASE INPUT SEGMENT OPTION FILE NAME? C2920A0  ..(2)
PLEASE INPUT USER'S NAME? SEIKO EPSON CORP.  ..(3)
PLEASE INPUT ANY COMMENT
(ONE LINE IS 50 CHR)? TOKYO DESIGN CENTER  ..(4)
? 421-8 HINO HINO-SHI TOKYO 191 JAPAN 
? TEL 0425-84-2551 
? FAX 0425-84-8512 
? 

```

#### Input file selection

(1) Will display the files on the current drive.  
(2) Enter the file name.  
(3) Enter the customer's company name.  
(4) Enter any comment.  
(Within 50 characters x 10 lines)

Then, move to the confirmation procedure for HEX file generation.

```

*** SOURCE FILE(S) ***
SEGMENT OPTION SOURCE FILE IS NOT FOUND. ..(5) -H option not use

*** SOURCE FILE(S) ***
SEGMENT OPTION DOCUMENT FILE IS NOT FOUND. ..(6) -H option use

```

In step (1), if no modifiable source exists, an error message (5) or (6) will be displayed and the program will be terminated. In step (2), if the specified file name is not found in the current drive, an error message (7) or (8) is displayed, prompting entry of other file name.

```

PLEASE INPUT SEGMENT OPTION SOURCE FILE NAME? C2920N0 
SEGMENT OPTION SOURCE FILE IS NOT FOUND. ..(7) -H option not use

PLEASE INPUT SEGMENT OPTION DOCUMENT FILE NAME? C2920N0 
SEGMENT OPTION DOCUMENT FILE IS NOT FOUND. ..(8) -H option use

```

```

END OF OPTION SETTING.
DO YOU MAKE HEX FILE (Y/N) ? Y  .. (1)

*** OPTION EPROM SELECT MENU ***

    1. 27C64
    2. 27C128
    3. 27C256
    4. 27C512

PLEASE SELECT NO.? 2  .. (2)

    2. 27C128  SELECTED

MAKING FILE IS COMPLETED.

```

***EPROM selection***

When selecting file is completed, the following message is output to ask the operator whether to generate the HEX file.

- (1) When debugging the program with the evaluation board, HEX file is needed, so enter "Y ". If "N " is entered, no HEX file is generated and only document file is generated.
- (2) For the option ROM selection menu displayed when "Y " is entered in Step (1), select the EPROM to be used for setting evaluation board options.

When a series of operations are complete, the SOG6292 generates files. If no error is committed while setting segment options, "MAKING FILE IS COMPLETED" will be displayed and the SOG6292 program will be terminated.

**■ Error messages**

Error message	Explanation
S (Syntax Error)	The data was written in an invalid format.
N (Segment No. Select Error)	The segment number outside the specificable range was specified.
R (RAM Address Select Error)	The segment memory address or data bit outside the specificable range was specified.
D (Duprication Error)	The same data (SEG port No., segment memory address, or data bit) was specified more then once.
Out Port Set Error	The output specifications were not set in units of two ports. Though DC output has been selected for output specification, data are described in COM1–COM3.

## 5.5 Sample Files

### ■ Example of segment option source file

```
;C292TS1.SEG, VER3.21
;LCD SEGMENT DECODE TABLE
;
 0 600 601 602 603 S
 1 610 611 612 613 S
 2 620 621 622 623 S
 3 630 631 632 633 S
 4 640 641 642 643 S
 5 650 651 652 653 S
 6 660 661 662 663 S
 7 670 671 672 673 S
 8 680 681 682 683 S
 9 690 691 692 693 S
10 6A0 6A1 6A2 6A3 S
11 6B0 6B1 6B2 6B3 S
12 6C0 6C1 6C2 6C3 S
13 6D0 6D1 6D2 6D3 S
14 6E0 6E1 6E2 6E3 S
15 6F0 6F1 6F2 6F3 S
16 700 701 702 703 S
17 710 711 712 713 S
18 720 721 722 723 S
19 730 731 732 733 S
20 740 741 742 743 S
21 750 751 752 753 S
```

### ■ Example of segment option document file

```
* E0C6292 SEGMENT OPTION DOCUMENT V 3.21
*
* FILE NAME      C292TS1S.DOC
* USER'S NAME    SEIKO EPSON CORP.
* INPUT DATE     94/01/19
*
*
* OPTION NO.12
*
* < LCD SEGMENT DECODE TABLE >
*
* SEG COM0 COM1 COM2 COM3 SPEC
*
 0 600 601 602 603 S
 1 610 611 612 613 S
 2 620 621 622 623 S
 3 630 631 632 633 S
 4 640 641 642 643 S
 5 650 651 652 653 S
 6 660 661 662 663 S
 7 670 671 672 673 S
 8 680 681 682 683 S
 9 690 691 692 693 S
10 6A0 6A1 6A2 6A3 S
11 6B0 6B1 6B2 6B3 S
12 6C0 6C1 6C2 6C3 S
13 6D0 6D1 6D2 6D3 S
14 6E0 6E1 6E2 6E3 S
15 6F0 6F1 6F2 6F3 S
16 700 701 702 703 S
17 710 711 712 713 S
18 720 721 722 723 S
19 730 731 732 733 S
20 740 741 742 743 S
21 750 751 752 753 S
\\END
```

Note End mark "¥END" may be used instead of "\\END" depending on the PC used. (The code of \ and ¥ is 5CH.)

# 6 ICE CONTROL SOFTWARE ICS6292

## 6.1 ICS6292 Outline

The In-Circuit Emulator (S5U1C62000H) connects the target board produced by the user via the evaluation board (S5U1C621C0E) and performs real time target system evaluation and debugging by passing through the RS-232C from the host computer and controlling it. The operation on the host computer side and ICE (S5U1C62000H) control is done through the ICE Control Software ICS6292.

The ICS6292 has a set of numerous and highly functional emulation commands which provide sophisticated break function, on-the-fly data display, history display, etc., and so perform a higher level of debugging.

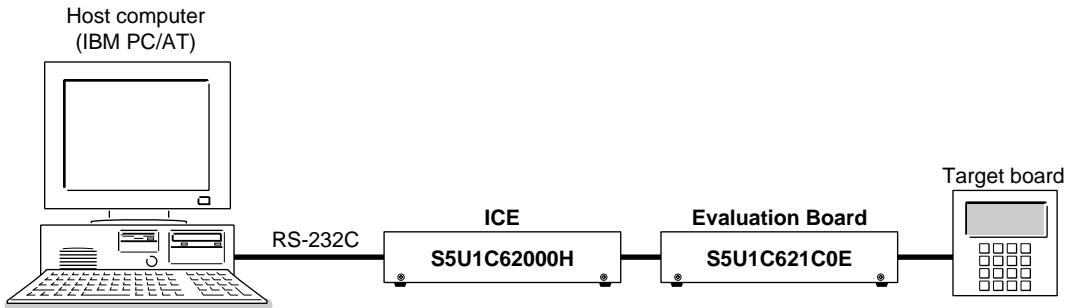

Fig. 6.1.1 Debugging system using ICE

(The evaluation board can be used as the evaluation board for the S1C62920 by modifying the function option HEX data generated from the FOG6292.)

☞ The functions of the ICE and commands are same as for the S1C62 Family. Refer to the "S1C62 Family Development Tool Reference Manual" for details.

## 6.2 ICS6292 Restrictions

Take the following precautions when using the ICS6292.

### ■ ROM Area

The ROM area is limited to a maximum address of 07FFH. Assigning data above the 07FFH address causes an error.

### ■ RAM Area

The RAM area is limited to a maximum address of 1FFH. However, as the following addresses are in the unused area, designation of this area with the ICE commands produces an error.

- 82H–90H, 93H–9FH, A1H–AFH, B1H, B3H, B5H, B7H–BFH, C0H, C2H–C5H, C7H, CBH–CFH, D7H–DFH, E0H–E7H, EBH–EFH, F2H, F5H–F7H, FAH and FDH–FFH in page 0 to 1
- 100H–15FH

(Refer to the "S1C62920 Technical Manual" for details.)

### ■ Undefined Code

The SLP instruction is not specified for the S1C62920 and so cannot be used.

### ■ OPTLD Command

In the ICS6292, OPTLD command can be used.

This command is used to load HEX files (function option and segment option data for LCD) in the evaluation board memory with the ICE.

Load of function option data: #OPTLD, 1, C292XXX

Load of segment option data: #OPTLD, 2, C292XXX

## OPTLD *READ HEXA DATA FILE*

---

**Format** #OPTLD, 1, <file name> [ ] ... (1)  
 #OPTLD, 2, <file name> [ ] ... (2)

**Function**

- (1) Load function option HEX file in the evaluation board function option data memory. It is HEX file output by the function option generator and has intel HEX format.
- (2) Load segment option HEX file in the evaluation board segment option data memory. It is HEX file output by the segment option generator and has intel HEX format. Loading time of a segment option HEX data is dependent on the OSC3 system clock. It takes about 5 to 10 minutes.

**Examples** #OPTLD, 1, C292XXX [ ] .... C292XXXF.HEX file is loaded in the function option data memory.  
 #OPTLD, 2, C292XXX [ ] .... C292XXXS.HEX file is loaded in the segment option data memory.

### 6.3 ICS6292 Quick Reference

#### Starting command and input/output files

☐ indicates the Return key.

- Execution file:** ICS6292B.BAT (ICS6292W.EXE)
- Starting command:** **ICS6292B (ICS6292W)**☐
- Input file:**
  - C292XXXL.HEX (Object file, low-order)
  - C292XXXH.HEX (Object file, high-order)
  - C292XXXD.HEX (Data RAM file)
  - C292XXXC.HEX (Control file)
  - C292XXXF.HEX (Function option HEX file)
  - C292XXXS.HEX (Segment option HEX file)
- Output file:**
  - C292XXXL.HEX (Object file, low-order)
  - C292XXXH.HEX (Object file, high-order)
  - C292XXXD.HEX (Data RAM file)
  - C292XXXC.HEX (Control file)

#### Display example

```

*** E0C6292 ICE CONTROL SOFTWARE. --- Ver 3.01 ***
EEEEEEEEEE PPPPPPPP SSSSSSSS 00000000 NNN NNN
EEEEEEEEEE PPPPPPPPPP SSS SSSS 000 000 NNNN NNN
EEE PPP PPP SSS SSS 000 000 NNNNNN NNN
EEE PPP PPP SSS 000 000 NNNNNN NNN
EEEEEEEEEE PPPPPPPPPP SSSSSSS 000 000 NNN NNN NNN
EEEEEEEEEE PPPPPPPP SSSS 000 000 NNN NNNNNN
EEE PPP SSS 000 000 NNN NNNNN
EEE PPP SSS SSS 000 000 NNN NNNN
EEEEEEEEEE PPP SSS SSS 000 000 NNN NNN
EEEEEEEEEE PPP SSSSSSS 00000000 NNN NN
(C) COPYRIGHT 1991 SEIKO EPSON CORP.
* ICE POWER ON RESET *
* DIAGNOSTIC TEST OK *
#
    
```

#### Start-up message

When ICS6292 is started, the start-up message is displayed, and a self-test is automatically performed. ICS6292 commands are awaited when the program is properly loaded and the # mark is displayed.

Debugging can be done by entering command after the # mark.

The ICS6292 program is terminated by entering the Q (Quit) command.

*Note* Confirm that the cables connected properly, then operate the ICS6292.

#### Error messages

Error message	Meaning	Recover procedure
* COMMUNICATION ERROR OR ICE NOT READY *	ICE is disconnected or power is OFF.	Switch OFF the host power supply, connect cable, and reapply power. Or switch ON power to ICE.
* TARGET DOWN (1) *	Evaluation board is disconnected. (Check at power ON)	Switch OFF power to ICE, and connect the evaluation board. Then, apply power to ICE.
* TARGET DOWN (2) *	Evaluation board is disconnected. (Check at command execution)	Switch OFF power to ICE, and connect the evaluation board. Then, apply power to ICE.
* UNDEFINED PROGRAM CODE EXIST *	Undefined code is detected in the program loaded from ROM or FD.	Convert ROM and FD data with the cross assembler, then restart the ICE.
* COMMAND ERROR *	A miss occurs by command input.	Reenter the proper command.
(No response after power on)	The ICE-to-HOST cable is disconnected on the host side.	Switch OFF the host power supply, connect cable, and reapply power.

## ■ ICE commands

Item No.	Function	Command Format	Outline of Operation		
1	Assemble	#A,a [↵]	Assemble command mnemonic code and store at address "a"		
2	Disassemble	#L,a1,a2 [↵]	Contents of addresses a1 to a2 are disassembled and displayed		
3	Dump	#DP,a1,a2 [↵]	Contents of program area a1 to a2 are displayed		
		#DD,a1,a2 [↵]	Content of data area a1 to a2 are displayed		
4	Fill	#FP,a1,a2,d [↵]	Data d is set in addresses a1 to a2 (program area)		
		#FD,a1,a2,d [↵]	Data d is set in addresses a1 to a2 (data area)		
5	Set Run Mode	#G,a [↵]	Program is executed from the "a" address		
		#TIM [↵]	Execution time and step counter selection		
		#OTF [↵]	On-the-fly display selection		
6	Trace	#T,a,n [↵]	Executes program while displaying results of step instruction from "a" address		
		#U,a,n [↵]	Displays only the final step of #T,a,n		
7	Break	#BA,a [↵]	Sets Break at program address "a"		
		#BAR,a [↵]	Breakpoint is canceled		
		#BD [↵]	Break condition is set for data RAM		
		#BDR [↵]	Breakpoint is canceled		
		#BR [↵]	Break condition is set for evaluation board CPU internal registers		
		#BRR [↵]	Breakpoint is canceled		
		#BM [↵]	Combined break conditions set for program data RAM address and registers		
		#BMR [↵]	Cancel combined break conditions for program data ROM address and registers		
		#BRES [↵]	All break conditions canceled		
		#BC [↵]	Break condition displayed		
		#BE [↵]	Enter break enable mode		
8	Move	#MP,a1,a2,a3 [↵]	Contents of program area addresses a1 to a2 are moved to addresses a3 and after		
		#MD,a1,a2,a3 [↵]	Contents of data area addresses a1 to a2 are moved to addresses a3 and after		
		9	Data Set	#SP,a [↵]	Data from program area address "a" are written to memory
				#SD,a [↵]	Data from data area address "a" are written to memory
		10	Change CPU Internal Registers	#DR [↵]	Display evaluation board CPU internal registers
#SR [↵]	Set evaluation board CPU internal registers				
#I [↵]	Reset evaluation board CPU				
#DXY [↵]	Display X, Y, MX and MY				
#SXY [↵]	Set data for X and Y display and MX, MY				

Item No.	Function	Command Format	Outline of Operation
11	History	#H,p1,p2 <input type="checkbox"/>	Display history data for pointer 1 and pointer 2
		#HB <input type="checkbox"/>	Display upstream history data
		#HG <input type="checkbox"/>	Display 21 line history data
		#HP <input type="checkbox"/>	Display history pointer
		#HPS,a <input type="checkbox"/>	Set history pointer
		#HC,S/C/E <input type="checkbox"/>	Sets up the history information acquisition before (S), before/after (C) and after (E)
		#HA,a1,a2 <input type="checkbox"/>	Sets up the history information acquisition from program area a1 to a2
		#HAR,a1,a2 <input type="checkbox"/>	Sets up the prohibition of the history information acquisition from program area a1 to a2
		#HAD <input type="checkbox"/>	Indicates history acquisition program area
		#HS,a <input type="checkbox"/>	Retrieves and indicates the history information which executed a program address "a"
		#HSW,a <input type="checkbox"/>	Retrieves and indicates the history information which wrote or read the data area address "a"
12	File	#RF,file <input type="checkbox"/>	Move program file to memory
		#RFD,file <input type="checkbox"/>	Move data file to memory
		#VF,file <input type="checkbox"/>	Compare program file and contents of memory
		#VFD,file <input type="checkbox"/>	Compare data file and contents of memory
		#WF,file <input type="checkbox"/>	Save contents of memory to program file
		#WFD,file <input type="checkbox"/>	Save contents of memory to data file
		#CL,file <input type="checkbox"/>	Load ICE set condition from file
		#CS,file <input type="checkbox"/>	Save ICE set condition to file
		#OPTLD,1,file <input type="checkbox"/>	Load function option data from file
#OPTLD,2,file <input type="checkbox"/>	Load segment option data from file		
13	Coverage	#CVD <input type="checkbox"/>	Indicates coverage information
		#CVR <input type="checkbox"/>	Clears coverage information
14	ROM Access	#RP <input type="checkbox"/>	Move contents of ROM to program memory
		#VP <input type="checkbox"/>	Compare contents of ROM with contents of program memory
		#ROM <input type="checkbox"/>	Set ROM type
15	Terminate ICE	#Q <input type="checkbox"/>	Terminate ICE and return to operating system control
16	Command Display	#HELP <input type="checkbox"/>	Display ICE instruction
17	Self Diagnosis	#CHK <input type="checkbox"/>	Report results of ICE self diagnostic test

means press the RETURN key.

# 7 MASK DATA CHECKER MDC6292

## 7.1 MDC6292 Outline

The Mask Data Checker MDC6292 is a software tool which checks the program data (C292XXXH.HEX and C292XXXL.HEX) and option data (C292XXXF.DOC and C292XXXS.DOC) created by the user and creates the data file (C6292XXX.PAn) for generating mask patterns. The user must send the file generated through this software tool to Seiko Epson.

Moreover, MDC6292 has the capability to restore the generated data file (C6292XXX.PA0) to the original file format.

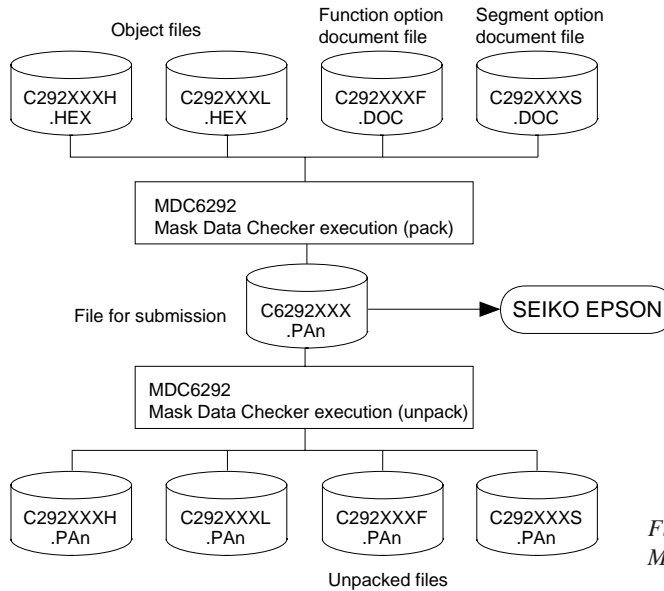

Fig. 7.1.1  
MDC6292 execution flow

☞ The operating method is same as for the S1C62 Family. Refer to the "S1C62 Family Development Tool Reference Manual" for details.

## 7.2 MDC6292 Quick Reference

### ■ Starting command and input/output files

**Execution file:** MDC6292.EXE

**Starting command:** MDC6292

indicates the Return key.

<b>Input file:</b>	C292XXXL.HEX (Object file, low-order)	] When packing
	C292XXXH.HEX (Object file, high-order)	
	C292XXXF.DOC (Function option document file)	
	C292XXXS.DOC (Segment option document file)	
	C6292XXX.PAn (Packed file)	
<b>Output file:</b>	C6292XXX.PAn (Packed file)	] When packing
	C292XXXL.PAn (Object file, low-order)	] When unpacking
	C292XXXH.PAn (Object file, high-order)	
	C292XXXF.PAn (Function option document file)	
	C292XXXS.PAn (Segment option document file)	

■ Display examples

```

*** E0C6292 PACK / UNPACK PROGRAM Ver 2.001 ***
EEEEEEEEEE PFFFFFFP SSSSSSS OOOOOOOO NNN NNN
EEEEEEEEEE PFFFFFFP SSS SSS OOO OOO NNNN NNN
EEE PFP PFP SSS SSS OOO OOO NNNNN NNN
EEE PFP PFP SSS OOO OOO NNNNN NNN
EEEEEEEEEE PFFFFFFP SSSSSSS OOO OOO NNN NNN NNN
EEEEEEEEEE PFFFFFFP SSSSSSS OOO OOO NNN NNNNN
EEE PFP SSS SSS OOO OOO NNN NNNNN
EEE PFP SSS SSS OOO OOO NNN NNNN
EEEEEEEEEE PFP SSSS SSS OOO OOO NNN NNN
EEEEEEEEEE PFP SSSSSSS OOOOOOOO NNN NN
    
```

(C) COPYRIGHT 1993 SEIKO EPSON CORP.

--- OPERATION MENU ---

1. PACK  
2. UNPACK

PLEASE SELECT NO.?

```

--- OPERATION MENU ---
1. PACK
2. UNPACK
PLEASE SELECT NO.? 1 [ ] ... (1)
C292XXXH.HEX -----+
C292XXXL.HEX -----+
C292XXXF.DOC -----+----- C292XXX.PAn (PACK FILE)
C292XXXS.DOC -----+
PLEASE INPUT PACK FILE NAME (C6292XXX.PAn) ? C62920A0.PA0 [ ] ... (2)
C2920A0H.HEX -----+
C2920A0L.HEX -----+
C2920A0F.DOC -----+----- C2920A0.PA0
C2920A0S.DOC -----+
    
```

**Start-up message**

When MDC6292 is started, the start-up message and operation menu are displayed. Here, the user is prompted to select operation options.

**Packing of data**

- (1) Select "1. PACK" in the operation menu.
- (2) Enter the file name.  
After submitting the data to Seiko Epson and there is a need to re-submit the data, increase the numeric value of "n" by one when the input is made.  
(Example: When re-submitting data after "C6292XXX.PA0" has been submitted, the pack file name should be entered as "C6292XXX.PA1".)

With this, the mask file (C6292XXX.PAn) is generated, and the MDC6292 program will be terminated. Submit this file to Seiko Epson.

*Note Don't use the data generated with the -N option of the Cross Assembler (ASM6292) as program data. If the program data generated with the -N option of the Cross Assembler is packed, following message is displayed.*

```

HEX DATA ERROR : DATA (NO FFh)
    
```

```

--- OPERATION MENU ---
1. PACK
2. UNPACK
PLEASE SELECT NO.? 2 [ ] ... (1)
PLEASE INPUT PACKED FILE NAME (C6292XXX.PAn) ? C62920A0.PA0 [ ] ... (2)
C62920A0.PA0 -----+----- C2920A0H.PA0
C62920A0.PA0 -----+----- C2920A0L.PA0
C62920A0.PA0 -----+----- C2920A0F.PA0
C62920A0.PA0 -----+----- C2920A0S.PA0
    
```

**Unpacking of data**

- (1) Select "2. UNPACK" in the operation menu.
- (2) Enter the packed file name.  
With this, the mask data file (C6292XXX.PAn) is restored to the original file format, and the MDC6292 program will be terminated.

Since the extension of the file name remains as "PAn", it must be renamed back to its original form ("HEX" and "DOC") in order to re-debug or modify the restored file.

## ■ Error messages

### Program data error

Error Message	Explanation
1. HEX DATA ERROR : NOT COLON.	There is no colon.
2. HEX DATA ERROR : DATA LENGTH. (NOT 00-20h)	The data length of 1 line is not in the 00-20H range.
3. HEX DATA ERROR : ADDRESS.	The address is beyond the valid range of the program ROM.
4. HEX DATA ERROR : RECORD TYPE. (NOT 00)	The record type of 1 line is not 00.
5. HEX DATA ERROR : DATA. (NOT 00-FFh)	The data is not in the range between 00H and 0FFH.
6. HEX DATA ERROR : TOO MANY DATA IN ONE LINE.	There are too many data in 1 line.
7. HEX DATA ERROR : CHECK SUM.	The checksum is not correct.
8. HEX DATA ERROR : END MARK.	The end mark is not : 0000001FF.
9. HEX DATA ERROR : DUPLICATE.	There is duplicate definition of data in the same address.
10. HEX DATA ERROR : DATA (NO FFh)	There is an undefined field in the HEX data.

### Function option data error

Error Message	Explanation
1. OPTION DATA ERROR : START MARK.	The start mark is not "OPTION". (during unpacking) *
2. OPTION DATA ERROR : OPTION NUMBER.	The option number is not correct.
3. OPTION DATA ERROR : SELECT NUMBER.	The option selection number is not correct.
4. OPTION DATA ERROR : END MARK.	The end mark is not "\\END" (packing) or "\\END" (unpacking).*

### Segment option data error

Error Message	Explanation
1. SEGMENT DATA ERROR : START MARK.	The start mark is not "SEGMENT". (during unpacking) *
2. SEGMENT DATA ERROR : DATA.	The segment data is not correct.
3. SEGMENT DATA ERROR : SEGMENT NUMBER.	The SEG No. is not correct.
4. SEGMENT DATA ERROR : SPEC.	The output specification of the SEG terminal is not correct.
5. SEGMENT DATA ERROR : END MARK.	The end mark is not "\\END" (packing) or "\\END" (unpacking).*

### File error

Error Message	Explanation
1. <File_name> FILE IS NOT FOUND.	The file is not found or the file number set in CONFIG.SYS is less than 10.
2. PACK FILE NAME (File_name) ERROR.	The packed input format for the file name is wrong.
3. PACKED FILE NAME (File_name) ERROR.	The unpacked input format for the file name is wrong.
4. VERSION NUMBER ERROR : X.DOC	FOG6292, SOG6292 different from the version No. has been used.

### System error

Error Message	Explanation
1. DIRECTORY FULL.	The directory is full.
2. DISK WRITE ERROR.	Writing on the disk is failed.

\* | sometimes appears as ¥, depending on the personal computer being used.

# APPENDIX A. S1C62920 INSTRUCTION SET

Classification	Mnemonic	Operand	Operation Code						Flag			Clock	Operation								
			B	A	9	8	7	6	5	4	3			2	1	0	I	D	Z	C	
Branch instructions	PSET	p	1	1	1	0	0	1	0	p4	p3	p2	p1	p0					5	NBP ← p4, NPP ← p3~p0	
	JP	s	0	0	0	0	s7	s6	s5	s4	s3	s2	s1	s0					5	PCB ← NBP, PCP ← NPP, PCS ← s7~s0	
		C, s	0	0	1	0	s7	s6	s5	s4	s3	s2	s1	s0					5	PCB ← NBP, PCP ← NPP, PCS ← s7~s0 if C=1	
		NC, s	0	0	1	1	s7	s6	s5	s4	s3	s2	s1	s0					5	PCB ← NBP, PCP ← NPP, PCS ← s7~s0 if C=0	
		Z, s	0	1	1	0	s7	s6	s5	s4	s3	s2	s1	s0					5	PCB ← NBP, PCP ← NPP, PCS ← s7~s0 if Z=1	
		NZ, s	0	1	1	1	s7	s6	s5	s4	s3	s2	s1	s0					5	PCB ← NBP, PCP ← NPP, PCS ← s7~s0 if Z=0	
	JPBA		1	1	1	1	1	1	1	0	1	0	0	0					5	PCB ← NBP, PCP ← NPP, PCSH ← B, PCSL ← A	
	CALL	s	0	1	0	0	s7	s6	s5	s4	s3	s2	s1	s0					7	M(SP-1) ← PCP, M(SP-2) ← PCSH, M(SP-3) ← PCSL+1 SP ← SP-3, PCP ← NPP, PCS ← s7~s0	
	CALZ	s	0	1	0	1	s7	s6	s5	s4	s3	s2	s1	s0					7	M(SP-1) ← PCP, M(SP-2) ← PCSH, M(SP-3) ← PCSL+1 SP ← SP-3, PCP ← 0, PCS ← s7~s0	
	RET		1	1	1	1	1	1	0	1	1	1	1	1					7	PCSL ← M(SP), PCSH ← M(SP+1), PCP ← M(SP+2) SP ← SP+3	
RETS		1	1	1	1	1	1	0	1	1	1	1	0					12	PCSL ← M(SP), PCSH ← M(SP+1), PCP ← M(SP+2) SP ← SP+3, PC ← PC+1		
RETD	l	0	0	0	1	l7	l6	l5	l4	l3	l2	l1	l0					12	PCSL ← M(SP), PCSH ← M(SP+1), PCP ← M(SP+2) SP ← SP+3, M(X) ← l3~l0, M(X+1) ← l7~l4, X ← X+2		
System control instructions	NOP5		1	1	1	1	1	1	1	1	1	0	1	1					5	No operation (5 clock cycles)	
	NOP7		1	1	1	1	1	1	1	1	1	1	1	1					7	No operation (7 clock cycles)	
	HALT		1	1	1	1	1	1	1	1	1	0	0	0					5	Halt (stop clock)	
Index operation instructions	INC	X	1	1	1	0	1	1	1	0	0	0	0	0					5	X ← X+1	
		Y	1	1	1	0	1	1	1	1	0	0	0	0					5	Y ← Y+1	
	LD	X, x	1	0	1	1	x7	x6	x5	x4	x3	x2	x1	x0					5	XH ← x7~x4, XL ← x3~x0	
		Y, y	1	0	0	0	y7	y6	y5	y4	y3	y2	y1	y0					5	YH ← y7~y4, YL ← y3~y0	
		XP, r	1	1	1	0	1	0	0	0	0	0	r1	r0					5	XP ← r	
		XH, r	1	1	1	0	1	0	0	0	0	1	r1	r0					5	XH ← r	
		XL, r	1	1	1	0	1	0	0	0	1	0	r1	r0					5	XL ← r	
		YP, r	1	1	1	0	1	0	0	1	0	0	r1	r0					5	YP ← r	
		YH, r	1	1	1	0	1	0	0	1	0	1	r1	r0					5	YH ← r	
		YL, r	1	1	1	0	1	0	0	1	1	0	r1	r0					5	YL ← r	
		r, XP	1	1	1	0	1	0	1	0	0	0	r1	r0					5	r ← XP	
		r, XH	1	1	1	0	1	0	1	0	0	1	r1	r0					5	r ← XH	
		r, XL	1	1	1	0	1	0	1	0	1	0	r1	r0					5	r ← XL	
		r, YP	1	1	1	0	1	0	1	1	0	0	r1	r0					5	r ← YP	
		r, YH	1	1	1	0	1	0	1	1	0	1	r1	r0					5	r ← YH	
		r, YL	1	1	1	0	1	0	1	1	1	0	r1	r0					5	r ← YL	
		ADC	XH, i	1	0	1	0	0	0	0	0	i3	i2	i1	i0		↑	↓		7	XH ← XH+i3~i0+C
			XL, i	1	0	1	0	0	0	0	1	i3	i2	i1	i0		↑	↓		7	XL ← XL+i3~i0+C
	YH, i		1	0	1	0	0	0	1	0	i3	i2	i1	i0		↑	↓		7	YH ← YH+i3~i0+C	
	YL, i		1	0	1	0	0	0	1	1	i3	i2	i1	i0		↑	↓		7	YL ← YL+i3~i0+C	

Classification	Mnemonic	Operand	Operation Code						Flag				Clock	Operation						
			B	A	9	8	7	6	5	4	3	2			1	0	I	D	Z	C
Index operation instructions	CP	XH, i	1	0	1	0	0	1	0	0	i3	i2	i1	i0	↓	↓	↓	7	XH-i3~i0	
		XL, i	1	0	1	0	0	1	0	1	i3	i2	i1	i0	↓	↓	↓	7	XL-i3~i0	
		YH, i	1	0	1	0	0	1	1	0	i3	i2	i1	i0	↓	↓	↓	7	YH-i3~i0	
		YL, i	1	0	1	0	0	1	1	1	i3	i2	i1	i0	↓	↓	↓	7	YL-i3~i0	
Data transfer instructions	LD	r, i	1	1	1	0	0	0	r1	r0	i3	i2	i1	i0				5	r ← i3~i0	
		r, q	1	1	1	0	1	1	0	0	r1	r0	q1	q0				5	r ← q	
		A, Mn	1	1	1	1	1	0	1	0	0	n3	n2	n1	n0				5	A ← M(n3~n0)
		B, Mn	1	1	1	1	1	0	1	1	n3	n2	n1	n0				5	B ← M(n3~n0)	
		Mn, A	1	1	1	1	1	0	0	0	n3	n2	n1	n0				5	M(n3~n0) ← A	
		Mn, B	1	1	1	1	1	0	0	1	n3	n2	n1	n0				5	M(n3~n0) ← B	
		LDPX	MX, i	1	1	1	0	0	1	1	0	i3	i2	i1	i0				5	M(X) ← i3~i0, X ← X+1
		r, q	1	1	1	0	1	1	1	0	r1	r0	q1	q0				5	r ← q, X ← X+1	
	LDPY	MY, i	1	1	1	0	0	1	1	1	i3	i2	i1	i0				5	M(Y) ← i3~i0, Y ← Y+1	
		r, q	1	1	1	0	1	1	1	1	r1	r0	q1	q0				5	r ← q, Y ← Y+1	
	LBPX	MX, l	1	0	0	1	17	16	15	14	13	12	11	10				5	M(X) ← 13~10, M(X+1) ← 17~14, X ← X+2	
Flag operation instructions	SET	F, i	1	1	1	1	0	1	0	0	i3	i2	i1	i0	↑	↑	↑	7	F ← F∨i3~i0	
	RST	F, i	1	1	1	1	0	1	0	1	i3	i2	i1	i0	↓	↓	↓	7	F ← F∧i3~i0	
	SCF		1	1	1	1	0	1	0	0	0	0	0	1			↑	7	C ← 1	
	RCF		1	1	1	1	0	1	0	1	1	1	1	0			↓	7	C ← 0	
	SZF		1	1	1	1	0	1	0	0	0	0	1	0			↑	7	Z ← 1	
	RZF		1	1	1	1	0	1	0	1	1	1	0	1			↓	7	Z ← 0	
	SDF		1	1	1	1	0	1	0	0	0	1	0	0			↑	7	D ← 1 (Decimal Adjuster ON)	
	RDF		1	1	1	1	0	1	0	1	1	0	1	1			↓	7	D ← 0 (Decimal Adjuster OFF)	
	EI		1	1	1	1	0	1	0	0	0	0	0	0			↑	7	I ← 1 (Enables Interrupt)	
	DI		1	1	1	1	0	1	0	1	0	1	1	1			↓	7	I ← 0 (Disables Interrupt)	
Stack operation instructions	INC	SP	1	1	1	1	1	1	0	1	1	0	1	1				5	SP ← SP+1	
	DEC	SP	1	1	1	1	1	1	0	0	1	0	1	1				5	SP ← SP-1	
	PUSH	r	1	1	1	1	1	1	0	0	0	0	r1	r0				5	SP ← SP-1, M(SP) ← r	
		XP	1	1	1	1	1	1	0	0	0	1	0	0				5	SP ← SP-1, M(SP) ← XP	
		XH	1	1	1	1	1	1	0	0	0	1	0	1				5	SP ← SP-1, M(SP) ← XH	
		XL	1	1	1	1	1	1	0	0	0	1	1	0				5	SP ← SP-1, M(SP) ← XL	
		YP	1	1	1	1	1	1	0	0	0	1	1	1				5	SP ← SP-1, M(SP) ← YP	
		YH	1	1	1	1	1	1	0	0	1	0	0	0				5	SP ← SP-1, M(SP) ← YH	
		YL	1	1	1	1	1	1	0	0	1	0	0	1				5	SP ← SP-1, M(SP) ← YL	
		F	1	1	1	1	1	1	0	0	1	0	1	0				5	SP ← SP-1, M(SP) ← F	
	POP	r	1	1	1	1	1	1	0	1	0	0	r1	r0				5	r ← M(SP), SP ← SP+1	
		XP	1	1	1	1	1	1	0	1	0	1	0	0				5	XP ← M(SP), SP ← SP+1	
		XH	1	1	1	1	1	1	0	1	0	1	0	1				5	XH ← M(SP), SP ← SP+1	
XL		1	1	1	1	1	1	0	1	0	1	1	0				5	XL ← M(SP), SP ← SP+1		
YP		1	1	1	1	1	1	0	1	0	1	1	1				5	YP ← M(SP), SP ← SP+1		

APPENDIX A. S1C62920 INSTRUCTION SET

Classification	Mnemonic	Operand	Operation Code						Flag			Clock	Operation							
			B	A	9	8	7	6	5	4	3			2	1	0	I	D	Z	C
Stack operation instructions	POP	YH	1	1	1	1	1	1	0	1	1	0	0	0					5	YH ← M(SP), SP ← SP+1
		YL	1	1	1	1	1	1	0	1	1	0	0	1					5	YL ← M(SP), SP ← SP+1
		F	1	1	1	1	1	1	0	1	1	0	1	0	↓	↓	↓	↓	5	F ← M(SP), SP ← SP+1
	LD	SPH, r	1	1	1	1	1	1	1	0	0	0	r1	r0					5	SPH ← r
		SPL, r	1	1	1	1	1	1	1	1	0	0	r1	r0					5	SPL ← r
		r, SPH	1	1	1	1	1	1	1	0	0	1	r1	r0					5	r ← SPH
		r, SPL	1	1	1	1	1	1	1	1	0	1	r1	r0					5	r ← SPL
Arithmetic instructions	ADD	r, i	1	1	0	0	0	0	r1	r0	i3	i2	i1	i0	★	↓	↓	↓	7	r ← r+i3~i0
		r, q	1	0	1	0	1	0	0	0	r1	r0	q1	q0	★	↓	↓	↓	7	r ← r+q
	ADC	r, i	1	1	0	0	0	1	r1	r0	i3	i2	i1	i0	★	↓	↓	↓	7	r ← r+i3~i0+C
		r, q	1	0	1	0	1	0	0	1	r1	r0	q1	q0	★	↓	↓	↓	7	r ← r+q+C
	SUB	r, q	1	0	1	0	1	0	1	0	r1	r0	q1	q0	★	↓	↓	↓	7	r ← r-q
		SBC	r, i	1	1	0	1	0	1	r1	r0	i3	i2	i1	i0	★	↓	↓	↓	7
	r, q		1	0	1	0	1	0	1	1	r1	r0	q1	q0	★	↓	↓	↓	7	r ← r-q-C
	AND	r, i	1	1	0	0	1	0	r1	r0	i3	i2	i1	i0		↓			7	r ← r∧i3~i0
		r, q	1	0	1	0	1	1	0	0	r1	r0	q1	q0		↓			7	r ← r∧q
	OR	r, i	1	1	0	0	1	1	r1	r0	i3	i2	i1	i0		↓			7	r ← r∨i3~i0
		r, q	1	0	1	0	1	1	0	1	r1	r0	q1	q0		↓			7	r ← r∨q
	XOR	r, i	1	1	0	1	0	0	r1	r0	i3	i2	i1	i0		↓			7	r ← r∨i3~i0
		r, q	1	0	1	0	1	1	1	0	r1	r0	q1	q0		↓			7	r ← r∨q
	CP	r, i	1	1	0	1	1	1	r1	r0	i3	i2	i1	i0	↓	↓			7	r-i3~i0
		r, q	1	1	1	1	0	0	0	0	r1	r0	q1	q0	↓	↓			7	r-q
	FAN	r, i	1	1	0	1	1	0	r1	r0	i3	i2	i1	i0		↓			7	r∧i3~i0
		r, q	1	1	1	1	0	0	0	1	r1	r0	q1	q0		↓			7	r∧q
	RLC	r	1	0	1	0	1	1	1	1	r1	r0	r1	r0	↓	↓			7	d3 ← d2, d2 ← d1, d1 ← d0, d0 ← C, C ← d3
	RRC	r	1	1	1	0	1	0	0	0	1	1	r1	r0	↓	↓			5	d3 ← C, d2 ← d3, d1 ← d2, d0 ← d1, C ← d0
	INC	Mn	1	1	1	1	0	1	1	0	n3	n2	n1	n0	↓	↓			7	M(n3~n0) ← M(n3~n0)+1
	DEC	Mn	1	1	1	1	0	1	1	1	n3	n2	n1	n0	↓	↓			7	M(n3~n0) ← M(n3~n0)-1
	ACPX	MX, r	1	1	1	1	0	0	1	0	1	0	r1	r0	★	↓	↓	↓	7	M(X) ← M(X)+r+C, X ← X+1
	ACPY	MY, r	1	1	1	1	0	0	1	0	1	1	r1	r0	★	↓	↓	↓	7	M(Y) ← M(Y)+r+C, Y ← Y+1
	SCPX	MX, r	1	1	1	1	0	0	1	1	1	0	r1	r0	★	↓	↓	↓	7	M(X) ← M(X)-r-C, X ← X+1
	SCPY	MY, r	1	1	1	1	0	0	1	1	1	1	r1	r0	★	↓	↓	↓	7	M(Y) ← M(Y)-r-C, Y ← Y+1
	NOT	r	1	1	0	1	0	0	r1	r0	1	1	1	1		↓			7	r ← r̄

Abbreviations used in the explanations have the following meanings.

**Symbols associated with registers and memory**

<b>A</b>	A register
<b>B</b>	B register
<b>X</b>	XHL register (low order eight bits of index register IX)
<b>Y</b>	YHL register (low order eight bits of index register IY)
<b>XH</b>	XH register (high order four bits of XHL register)
<b>XL</b>	XL register (low order four bits of XHL register)
<b>YH</b>	YH register (high order four bits of YHL register)
<b>YL</b>	YL register (low order four bits of YHL register)
<b>XP</b>	XP register (high order four bits of index register IX)
<b>YP</b>	YP register (high order four bits of index register IY)
<b>SP</b>	Stack pointer SP
<b>SPH</b>	High-order four bits of stack pointer SP
<b>SPL</b>	Low-order four bits of stack pointer SP
<b>MX, M(X)</b>	Data memory whose address is specified with index register IX
<b>MY, M(Y)</b>	Data memory whose address is specified with index register IY
<b>Mn, M(n)</b>	Data memory address 000H–00FH (address specified with immediate data n of 00H–0FH)
<b>M(SP)</b>	Data memory whose address is specified with stack pointer SP
<b>r, q</b>	Two-bit register code r, q is two-bit immediate data; according to the contents of these bits, they indicate registers A, B, and MX and MY (data memory whose addresses are specified with index registers IX and IY)

r		q		Register specified
r1	r0	q1	q0	
0	0	0	0	A
0	1	0	1	B
1	0	1	0	MX
1	1	1	1	MY

**Symbols associated with program counter**

<b>NBP</b>	New bank pointer
<b>NPP</b>	New page pointer
<b>PCB</b>	Program counter bank
<b>PCP</b>	Program counter page
<b>PCS</b>	Program counter step
<b>PCSH</b>	Four high order bits of PCS
<b>PCSL</b>	Four low order bits of PCS

**Symbols associated with flags**

<b>F</b>	Flag register (I, D, Z, C)
<b>C</b>	Carry flag
<b>Z</b>	Zero flag
<b>D</b>	Decimal flag
<b>I</b>	Interrupt flag
↓	Flag reset
↑	Flag set
↕	Flag set or reset

**Associated with immediate data**

<b>p</b>	Five-bit immediate data or label 00H–1FH
<b>s</b>	Eight-bit immediate data or label 00H–0FFH
<b>l</b>	Eight-bit immediate data 00H–0FFH
<b>i</b>	Four-bit immediate data 00H–0FH

**Associated with arithmetic and other operations**

+	Add
-	Subtract
∧	Logical AND
∨	Logical OR
⊕	Exclusive-OR
★	Add-subtract instruction for decimal operation when the D flag is set

# APPENDIX B. S1C62920 RAM MAP

RAM map - 1 (000H-07FH)

PROGRAM NAME:		0	1	2	3	4	5	6	7	8	9	A	B	C	D	E	F	
		L																
0	0	NAME MSB																
		LSB																
1	1	NAME MSB																
		LSB																
2	2	NAME MSB																
		LSB																
3	3	NAME MSB																
		LSB																
4	4	NAME MSB																
		LSB																
5	5	NAME MSB																
		LSB																
6	6	NAME MSB																
		LSB																
7	7	NAME MSB																
		LSB																





Display memory map (160H–17FH)

PROGRAM NAME:		0	1	2	3	4	5	6	7	8	9	A	B	C	D	E	F	
		L																
16	NAME																	
	MSB																	
7	NAME																	
	MSB																	
	LSB																	
	LSB																	



# APPENDIX C. S1C62920 I/O MEMORY MAP

## I/O memory map - 1

Address *6	Register				Name	Init *1	1	0	Comment
	D3	D2	D1	D0					
80H	0	0	SVDDT	SVDON	0 *5	- *2			Unused
	R			R/W	0 *5	- *2			Unused
81H	0	0	CLKCHG	OSCC	0 *5	- *2			Supply voltage detection data
	R			R/W	0 *5	- *2			SVD circuit On/Off
91H	K03	K02	K01	K00	K03	- *2	High	Low	Input port K00-K03
	R				K02	- *2	High	Low	
92H	KCP03	KCP02	KCP01	KCP00	K01	- *2	High	Low	Input comparison register (K00-K03)
	R/W				K00	- *2	High	Low	
A0H	R03 (BZ)	R02 (FOUT)	R01	R00	KCP03	1			Output port R03
	R/W				KCP02	1			
B0H	IOC03	IOC02	IOC01	IOC00	(BZ)	0	High	Low	I/O control register (P00-P03)
	R/W				(FOUT)	0	On	Off	
B2H	P03	P02	P01	P00	R02	0	High	Low	I/O port P00-P03
	R/W				R01	0	High	Low	
B4H	IOC13	IOC12	IOC11	IOC10	R00	0	High	Low	I/O control register (P10-P13)
	R/W				IOC03	0	Output	Input	
B6H	P13	P12	P11	P10	IOC02	0	Output	Input	I/O port P10-P13
	R/W				IOC01	0	Output	Input	
B6H	P13	P12	P11	P10	IOC00	0	Output	Input	I/O port P10-P13
	R/W				P03	1	High	Low	

### Remarks

\*1 Initial value at the time of initial reset

\*2 Not set in the circuit

\*3 Undefined

\*4 Reset (0) immediately after being read

\*5 Constantly "0" when being read

\*6 Page switching in I/O memory is not necessary

I/O memory map - 2

Address *6	Register				Name	Init *1	1	0	Comment
	D3	D2	D1	D0					
C1H	0	0	LOFF	LPWR	0 *5	- *2			Unused
	R		R/W		0 *5	- *2			Unused
C6H	0	0	0	WDRST	LOFF	0	All off	Normal	LCD display control
	R		W		LPWR	0	On	Off	LCD power supply On/Off
C8H	0	0	TMRUN	TMRST	0 *5	- *2			Unused
	R		R/W	W	0 *5	- *2			Unused
C9H	TM3	TM2	TM1	TM0	0 *5	- *2			Unused
	R				0 *5	- *2			Unused
CAH	TM7	TM6	TM5	TM4	0 *5	- *2			Unused
	R				0 *5	- *2			Unused
D0H	DBGOS	RFDBG	RFCLK	0	0	0	Sensor	Ref.-R	R/F converter debugging element selection
	R/W		R		0	0	Debug	Normal	R/F converter debug mode selection
D1H	0	0	SENS1	SENS0	0 *5	- *2			Unused
	R		R/W		0 *5	- *2			Unused
D2H	OVTBC	OVMC	RFRUN	0	0	0	Overflow	Non-over	Time base counter overflow flag
	R/W		R		0	0	Overflow	Non-over	Measurement counter overflow flag
D3H	MC03	MC02	MC01	MC00	0 *5	- *2			Unused
	R/W				0 *5	- *2			Unused
D4H	MC07	MC06	MC05	MC04	MC03	- *3			Measurement counter MC00-MC03
	R/W				MC02	- *3			
D5H	MC11	MC10	MC09	MC08	MC01	- *3			Measurement counter MC04-MC07
	R/W				MC00	- *3			
D6H	MC15	MC14	MC13	MC12	MC07	- *3			Measurement counter MC08-MC11
	R/W				MC11	- *3			
D6H	MC15	MC14	MC13	MC12	MC10	- *3			Measurement counter MC12-MC15
	R/W				MC09	- *3			
D6H	MC15	MC14	MC13	MC12	MC08	- *3			Measurement counter MC12-MC15
	R/W				MC08	- *3			

I/O memory map - 3

address *6	Register				Name	Init *1	1	0	Comment
	D3	D2	D1	D0					
E8H	SCS0	0	SCTRG	ESIF	SCS0 0 *5	0 - *2	FOUT	Slave	Serial I/F clock mode selection Unused
	R/W	R	R/W		SCTRG(W) SCTRG(R)	- *2 0	Trigger Run	- Stop	Serial I/F clock trigger (writing) Serial I/F clock status (reading)
					ESIF	0	SIF port	I/O port	P1 port function selection
						0			
E9H	SD3	SD2	SD1	SD0	SD3	- *2			MSB Serial I/F data (low-order 4 bits)
	R/W				SD2	- *2			
					SD1	- *2			LSB
EAH	SD7	SD6	SD5	SD4	SD7	- *2			MSB Serial I/F data (high-order 4 bits)
	R/W				SD6	- *2			
					SD5	- *2			LSB
					SD4	- *2			
F0H	0	0	0	EISIF	0 *5	- *2			Unused
	R			R/W	0 *5	- *2			Unused
					EISIF	0	Enable	Mask	Interrupt mask register (Serial I/F)
F1H	0	0	0	EIRF	0 *5	- *2			Unused
	R			R/W	0 *5	- *2			Unused
					EIRF	0	Enable	Mask	Interrupt mask register (R/F converter)
F3H	0	0	0	EIK0	0 *5	- *2			Unused
	R			R/W	0 *5	- *2			Unused
					EIK0	0	Enable	Mask	Interrupt mask register (K00-K03)
F4H	0	EIT2	EIT1	EIT0	0 *5	- *2	Enable	Mask	Unused
	R	R/W			EIT2	0	Enable	Mask	Interrupt mask register (Clock timer 2 Hz)
					EIT1	0	Enable	Mask	Interrupt mask register (Clock timer 8 Hz)
F8H					EIT0	0	Enable	Mask	Interrupt mask register (Clock timer 32 Hz)
	0	0	0	ISIF	0 *5	- *2			Unused
	R				0 *5	- *2			Unused
					ISIF *4	0	Yes	No	Interrupt factor flag (Serial I/F)
F9H	0	0	0	IRF	0 *5	- *2			Unused
	R				0 *5	- *2			Unused
					IRF *4	0	Yes	No	Interrupt factor flag (R/F converter)
FBH	0	0	0	IK0	0 *5	- *2			Unused
	R				0 *5	- *2			Unused
					IK0 *4	0	Yes	No	Interrupt factor flag (K00-K03)
FCH	0	IT2	IT1	IT0	0 *5	- *2			Unused
	R				IT2 *4	0	Yes	No	Interrupt factor flag (Clock timer 2 Hz)
					IT1 *4	0	Yes	No	Interrupt factor flag (Clock timer 8 Hz)
					IT0 *4	0	Yes	No	Interrupt factor flag (Clock timer 32 Hz)

# APPENDIX D. TROUBLESHOOTING

Tool	Problem	Remedy measures
ICE S5U1C62000H	Nothing appears on the screen, or nothing works, after activation.	Check the following and remedy if necessary: <ul style="list-style-type: none"> <li>• Is the RS-232C cable connected correctly?</li> <li>• Is the RS-232C driver installed?</li> <li>• Is MODE.COM on the disk?</li> <li>• Is the execution file correct? PC-DOS ICS6292W.EXE</li> <li>• Is the DOS version correct? PC-DOS Ver. 2.1 or later</li> <li>• Is the DIP switches that set the baud rate of the main ICE unit set correctly?</li> <li>• Is the fuse of the ICE cut off?</li> </ul>
	The ICE fuse cut immediately after activation.	Check the following and remedy if necessary: <ul style="list-style-type: none"> <li>• Are connectors F1 and F5 connected to the evaluation board correctly?</li> <li>• Is the target board power short-circuiting?</li> </ul>
	<ILLEGAL VERSION ICE6200> appears on the screen immediately after activation.	The wrong version of ICE is being used. Use the latest version.
	<ILLEGAL VERSION PARAMETER FILE> appears on the screen immediately after activation.	The wrong version of ICS6292P.PAR is being used. Use the latest version.
	Immediate values A (10) and B (11) cannot be entered correctly with the A command.	The A and B registers are reserved for the entry of A and B. Write 0A and 0B when entering A (10) and B (11). <i>Example:</i> LD A, B Data in the B register is loaded into the A register. LD B, 0A Immediate value A is loaded into the B register.
	<UNUSED AREA> is displayed by the SD command.	This message is output when the address following one in which data is written is unused. It does not indicate a problem. Data is correctly set in areas other than the read-only area.
	You can not do a real-time run in break-trace mode.	Since the CPU stops temporarily when breaking conditions are met, executing in a real-time is not performed.
	Output from the evaluation board is impossible when data is written to the I/O memory for Buzzer and Fout output with the ICE command.	Output is possible only in the real-time run mode.
SOG6292	An R error occurs although the address is correctly set in the segment source file.	Check the following and remedy if necessary: <ul style="list-style-type: none"> <li>• Does the address symbol use capital letters?</li> </ul>

Tool	Problem	Remedy measures
ASM6292	An R error occurs although the final page is passed.	The cross assembler is designed to output "R error" every time the page is changed. Use a pseudo-instruction to set the memory, such as ORG or PAGE, to change the page. See "Memory setting pseudo-instructions" in the cross assembler manual.
MDC6292	Activation is impossible.	Check the following and remedy if necessary: <ul style="list-style-type: none"> <li>• Is the number of files set at ten or more in OS environment file CONFIG.SYS?</li> </ul>
Evaluation board S5U1C621C0E	The evaluation board does not work when it is used independently.	Check the following and remedy if necessary: <ul style="list-style-type: none"> <li>• Has the EPROM for F.HEX and S.HEX been replaced by the EPROM for the target?</li> <li>• Is the EPROM for F.HEX and S.HEX installed correctly?</li> <li>• Is the appropriate voltage being supplied? (5V DC, 3A, or more)</li> <li>• Are the program ROMs (H and L) installed correctly?</li> <li>• Is data written from address 4000H? (When the 27C256 is used as the program ROM)</li> </ul>
	Target segment does not light.	Check the following and remedy if necessary: <ul style="list-style-type: none"> <li>• Is an EPROM with an access time of 250 ns or less being used for S.HEX.</li> <li>• Has the VADJ VR inside the evaluation board top cover been turned to a lower setting?</li> </ul>

# EPSON International Sales Operations

---

## AMERICA

---

### EPSON ELECTRONICS AMERICA, INC.

#### - HEADQUARTERS -

150 River Oaks Parkway  
San Jose, CA 95134, U.S.A.  
Phone: +1-408-922-0200 Fax: +1-408-922-0238

#### - SALES OFFICES -

##### West

1960 E. Grand Avenue  
El Segundo, CA 90245, U.S.A.  
Phone: +1-310-955-5300 Fax: +1-310-955-5400

##### Central

101 Virginia Street, Suite 290  
Crystal Lake, IL 60014, U.S.A.  
Phone: +1-815-455-7630 Fax: +1-815-455-7633

##### Northeast

301 Edgewater Place, Suite 120  
Wakefield, MA 01880, U.S.A.  
Phone: +1-781-246-3600 Fax: +1-781-246-5443

##### Southeast

3010 Royal Blvd. South, Suite 170  
Alpharetta, GA 30005, U.S.A.  
Phone: +1-877-EEA-0020 Fax: +1-770-777-2637

## EUROPE

---

### EPSON EUROPE ELECTRONICS GmbH

#### - HEADQUARTERS -

Riesstrasse 15  
80992 Munich, GERMANY  
Phone: +49-(0)89-14005-20 Fax: +49-(0)89-14005-110

#### SALES OFFICE

Altstadtstrasse 176  
51379 Leverkusen, GERMANY  
Phone: +49-(0)2171-5045-0 Fax: +49-(0)2171-5045-10

#### UK BRANCH OFFICE

Unit 2.4, Doncastle House, Doncastle Road  
Bracknell, Berkshire RG12 8PE, ENGLAND  
Phone: +44-(0)1344-381700 Fax: +44-(0)1344-381701

#### FRENCH BRANCH OFFICE

1 Avenue de l'Atlantique, LP 915 Les Conquerants  
Z.A. de Courtaboeuf 2, F-91976 Les Ulis Cedex, FRANCE  
Phone: +33-(0)1-64862350 Fax: +33-(0)1-64862355

#### BARCELONA BRANCH OFFICE

**Barcelona Design Center**  
Edificio Prima Sant Cugat  
Avda. Alcalde Barrils num. 64-68  
E-08190 Sant Cugat del Vallès, SPAIN  
Phone: +34-93-544-2490 Fax: +34-93-544-2491

## ASIA

---

### EPSON (CHINA) CO., LTD.

28F, Beijing Silver Tower 2# North RD DongSanHuan  
ChaoYang District, Beijing, CHINA  
Phone: 64106655 Fax: 64107319

#### SHANGHAI BRANCH

4F, Bldg., 27, No. 69, Gui Jing Road  
Caohejing, Shanghai, CHINA  
Phone: 21-6485-5552 Fax: 21-6485-0775

### EPSON HONG KONG LTD.

20/F., Harbour Centre, 25 Harbour Road  
Wanchai, Hong Kong  
Phone: +852-2585-4600 Fax: +852-2827-4346  
Telex: 65542 EPSCO HX

### EPSON TAIWAN TECHNOLOGY & TRADING LTD.

10F, No. 287, Nanking East Road, Sec. 3  
Taipei  
Phone: 02-2717-7360 Fax: 02-2712-9164  
Telex: 24444 EPSONTB

#### HSINCHU OFFICE

13F-3, No. 295, Kuang-Fu Road, Sec. 2  
HsinChu 300  
Phone: 03-573-9900 Fax: 03-573-9169

### EPSON SINGAPORE PTE., LTD.

No. 1 Temasek Avenue, #36-00  
Millenia Tower, SINGAPORE 039192  
Phone: +65-337-7911 Fax: +65-334-2716

### SEIKO EPSON CORPORATION KOREA OFFICE

50F, KLI 63 Bldg., 60 Yoido-dong  
Youngdeungpo-Ku, Seoul, 150-763, KOREA  
Phone: 02-784-6027 Fax: 02-767-3677

### SEIKO EPSON CORPORATION

#### ELECTRONIC DEVICES MARKETING DIVISION

##### Electronic Device Marketing Department

##### IC Marketing & Engineering Group

421-8, Hino, Hino-shi, Tokyo 191-8501, JAPAN  
Phone: +81-(0)42-587-5816 Fax: +81-(0)42-587-5624

##### ED International Marketing Department Europe & U.S.A.

421-8, Hino, Hino-shi, Tokyo 191-8501, JAPAN  
Phone: +81-(0)42-587-5812 Fax: +81-(0)42-587-5564

##### ED International Marketing Department Asia

421-8, Hino, Hino-shi, Tokyo 191-8501, JAPAN  
Phone: +81-(0)42-587-5814 Fax: +81-(0)42-587-5110

**SEIKO EPSON CORPORATION**  
**ELECTRONIC DEVICES MARKETING DIVISION**

■ EPSON Electronic Devices Website

<http://www.epson.co.jp/device/>