

IMU (Inertial Measurement Unit) CAN INTERFACE

■ GENERAL DESCRIPTION

The M-G552PJ1 is a small form factor inertial measurement unit (IMU) with 6 degrees of freedom: tri-axial angular rates and linear accelerations, and provides high-stability and high-precision measurement capabilities with the use of high-precision compensation technology. With Controller Area Network (CAN) interface support for host communication, the M-G552PJ1 reduces technical barriers for users to introduce inertial measurement and minimizes design resources to implement inertial movement analysis and control applications. This unit is packaged in a water-proof and dust-proof metallic case. It is suitable for use in industrial and heavy-duty applications.

The M-G552PJ1 features a built-in attitude angle output function using an extended Kalman filter optimized for high-speed operation and highly accurate attitude angle (Roll/Pitch). This exceptional real time performance is achieved using our unique DSP processing architecture for efficiency, and low power consumption. The application or system level power consumption and complexity can be reduced by offloading the high-speed processing from the host system that would otherwise be necessary to achieve highly dynamic posture angle.

The features of the IMU such as high stability, high precision, and small size make it easy to create and differentiate applications in various fields of industrial systems.

■ FEATURES

Item	Specification
Sensor	
Integrated sensor	SEIKO EPSON inertial measurement sensor Low-noise, High-stability Gyro bias instability : 1.2 °/h Angular random walk : 0.08 °/√h Initial bias error : 360 °/h (1σ) / 4mG(1σ) 6 Degree of freedom Triple Gyroscope : ±450 °/s Tri-axis Accelerometer : ±10 G Tilt function Inclination mode : ±80 ° Euler mode: ±180 °(Pitch), ±45 °(Roll) Resolution: 0.01 °, Static :±0.2 ° (1σ), Dynamic :±0.2 ° (1σ) 16bit data resolution Calibrated stability (Bias, Scale factor, Axial alignment)
Output data rate	100 sps (Default) Up to 200 sps (When attitude angle output is enabled) Up to 1000 sps (When attitude angle output is disabled)
LPF	Built-in moving average filter and FIR Kaiser filter
Interface	
Protocol	J1939 compatible
Physical layer	ISO11898-2 (High speed CAN)
Frame format	CAN2.0B 29 bit-ID
Bit rate	250k bps or 500k bps
Node-ID	128 (programmable)
Other function	
Indicator	Green-LED / Red-LED
General Specification	
Voltage supply	9 V to 32 V
Power consumption	32 mA (Vin=12V, default setting)
Operating temperature range	-30 °C to +80 °C
External dimension	
Outer packaging	Overall metallic shield case
Size	65 x 60 x 30 mm ³ (Not including projection.)
Weight	115 g
Interface connector	CAN connector: 5-pos, M12, water-proof

Item	Specification
Water-proof , Dust-proof:	IP67 equivalent
Regulation (Applicable only for Mass production)	
EU	CE marking (EN61326/RoHS Directive) Class A
USA	FCC part15B Class A

■ APPLICATIONS

- Motion and vibration measurement
- Platform stabilization
- Attitude detection for unmanned systems
- Vibration control and stabilization

Appendix1. CONNECTOR SPECIFICATIONS

Connector specification

Model number	SACC-DSI-MS-5CON-M12-SCO SH
Manufacturer	PHOENIX CONTACT

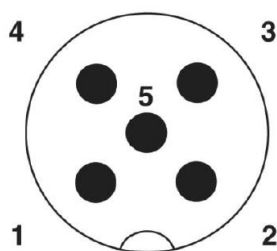

Terminal Layout

Terminal Function

No	Pin Name	I/O	Description
1	CAN_SHLD	-	CAN shield (*1)
2	CAN_V+	I	External power supply (9-32V)
3	CAN_GND	-	Ground
4	CAN_H	I/O	CAN H bus line
5	CAN_L	I/O	CAN L bus line

Notice: This unit should be connected to a connector that satisfies at least the IP67 water and dust proof specification.

(*1) CAN_SHLD is connected to the case.

Appendix2. J1939 MESSAGE OVERVIEW

Communication Settings

Item	Value	Note
CAN bit rate	250k bps / 500k bps	
CAN 29bit ID	-	CAN 11bits ID is ignored.
Address	128 (0x80)	Address is programmable.

Name Field

Field Name (J1939)	No. of bits	Byte No.	Value	Description
Arbitrary address capable	1	8	1	"Arbitrary address capable"
Industry group	3	8	0	"Global"
Vehicle system instance	4	8	0	
Vehicle system	7	7	0	"Non-specific system"
Reserved	1	7	0	
Function	8	6	145 (dec)	"Inertial Sensor"
Function Instance	5	5	0	
ECU Instance	3	5	1	
Manufacturer code	11	4,3	650 (dec)	"Seiko Epson Corp."
Identity number	21	3,2,1	xxxx	Unique number

Predefined Messages

Message Name	Direction	Priority	PGN	Description
Address claimed	in/out	6	60928 (0x00EE00)	Claim an address to use.

Proprietary Messages

Message Name	Direction	Priority	PGN	Description
Command	input	6	61184 (0x00EF00)	Command to the device.
Response	output	6	65504 (0x00FFE0)	Response for a command from the device.
SOUT1	output	6	65505 (0x00FFE1)	Angular rate data output
SOUT2	output	6	65506 (0x00FFE2)	Acceleration data output
SOUT4	output	6	65508 (0x00FFE4)	Temperature data output
SOUT5	output	6	65509 (0x00FFE5)	Time data output
SOUT7	output	6	65511 (0x00FFE7)	Attitude angle data output

OUTLINE DIMENSION

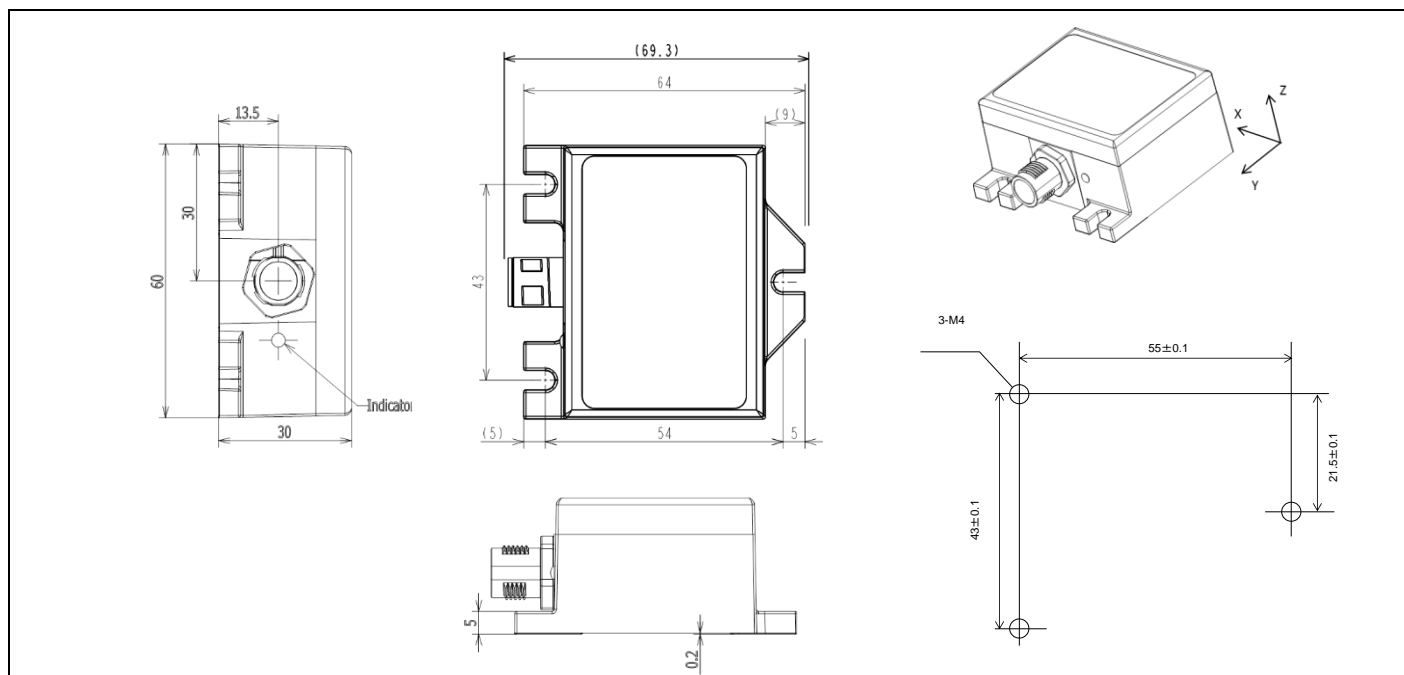

Outline Dimensions (millimeters)

NOTICE:

No part of this material may be reproduced or duplicated in any form or by any means without the written permission of Seiko Epson. Seiko Epson reserves the right to make changes to this material without notice. Seiko Epson does not assume any liability of any kind arising out of any inaccuracies contained in this material or due to its application or use in any product or circuit. This product must not be used in the application and/or equipment that demands extremely high reliability and where its failure may threaten human life or property (for example, aerospace equipment, submarine repeater, nuclear power control equipment, life support equipment, medical equipment, transportation control equipment, rail vehicles, personal cars, etc.). Therefore, Seiko Epson Corporation will not be liable for any and all damages caused by using this product for those applications and/or equipment. Moreover, no license to any intellectual property rights is granted by implication or otherwise, and there is no representation or warranty that anything made in accordance with this material will be free from any patent or copyright infringement of a third party. When exporting the products or technology described in this material, you should comply with the applicable export control laws and regulations and follow the procedures required by such laws and regulations. You are requested not to use, to resell, to export and/or to otherwise dispose of the products (and any technical information furnished, if any) for the development and/or manufacture of weapon of mass destruction or for other military purposes.

All brands or product names mentioned herein are trademarks and/or registered trademarks of their respective companies.

©Seiko Epson Corporation 2021, All rights reserved

SEIKO EPSON CORPORATION

DEVICE SALES & MARKETING DEPT.

29th Floor, JR Shinjuku Miraina Tower, 4-1-6 Shinjuku, Shinjuku-ku,
Tokyo, 160-8801, Japan
Phone: +81-3-6682-4322 FAX: +81-3-6682-5016

First issue May, 2020 in Japan
Revised: Jul. 2021

Rev.1.2